



**D'ANDREA**<sup>®</sup>  
TECHNOLOGY FOR HIGH PRECISION

# TOOLS HEADS 2023



Golden Compass  
award for industrial design



**D'ANDREA®**  
TECHNOLOGY FOR HIGH PRECISION

## MHD' Linea

PAG. 6-27



PAG. 8-11 ATTACCHI BASE - BR - BMD

PAG. 12 PR - RD - RAV

PAG. 14-15 **TS**

PAG. 18-26 TESTAROSSA **TRM / TRE / TRC**

PAG. 27 ADATTATORI

## HT Linea

PAG. 42-43



## PSC Linea

PAG. 28-39



PAG. 30-31 ATTACCHI BASE - PR - RD

PAG. 31-33 **PSC - TS**

PAG. 34 ADATTATORI

PAG. 35-39 TESTAROSSA **PSC - TRM**

## MONOforce

PAG. 44-45



## MONOd'

PAG. 46



PAG. 47



## TCD Linea

PAG. 40-41



## U-TRONIC

PAG. 60-68



### RICAMBI



PAG. 48-53

### DATI TECNICI

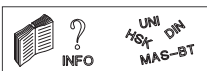

PAG. 54-56

### INSERTI



PAG. 58-59

# NEL SEGNO DELLA PRECISIONE

D'ANDREA S.p.A. è un'azienda italiana leader mondiale nella produzione di accessori di alta precisione per macchine utensili, fondata nel 1951 da Marino D'Andrea, che iniziò l'attività con l'introduzione della prima testa a sfacciare e barenare (TA). Il marchio D'Andrea è un brand internazionalmente riconosciuto, attraverso una rete distributiva presente in oltre 40 Paesi, per la qualità e l'affidabilità dei prodotti.

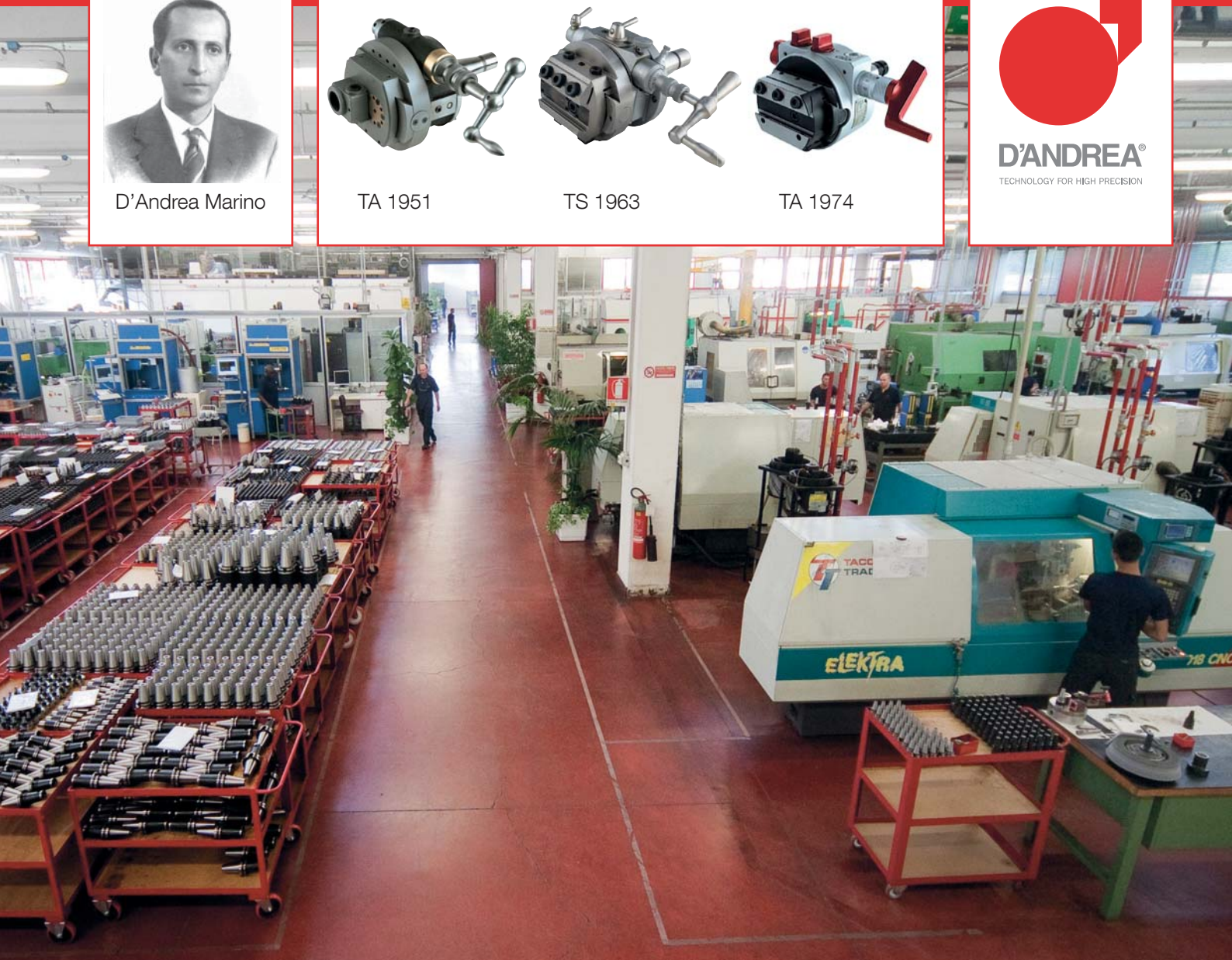
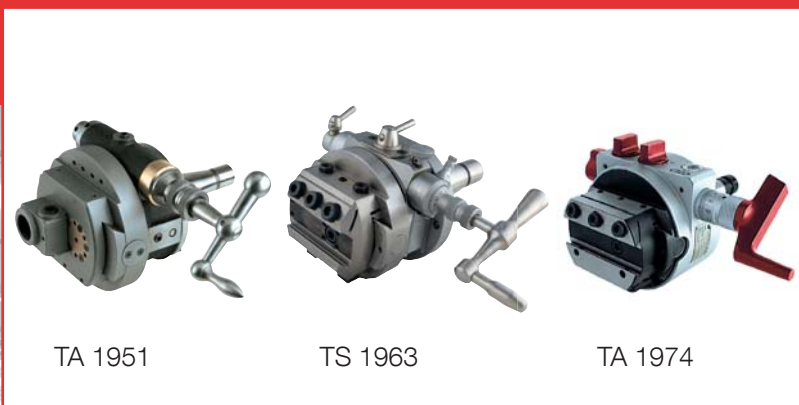

La produzione si divide tra la sede di Lainate, alle porte di Milano, coi suoi 7.000 mq di officina e uffici direzionali e lo stabilimento di Castel Del Giudice (Isernia) dove la D'ANDREA MOLISE produce, gran parte dei semilavorati dei componenti che vengono successivamente finiti, montati e collaudati nella sede principale.

Una parte cospicua del profitto è reinvestito in Ricerca e Sviluppo di nuovi prodotti che, grazie a soluzioni tecnologiche avanzate, soddisfano una domanda molto qualificata. Un team tecnico-commerciale dedicato permette una veloce esecuzione di progetti speciali su specifiche del cliente. Negli anni, il range di barenatura e alesatura è arrivato a coprire dai diametri più piccoli (2.5 mm) ai grandi diametri (fino a 3 metri).

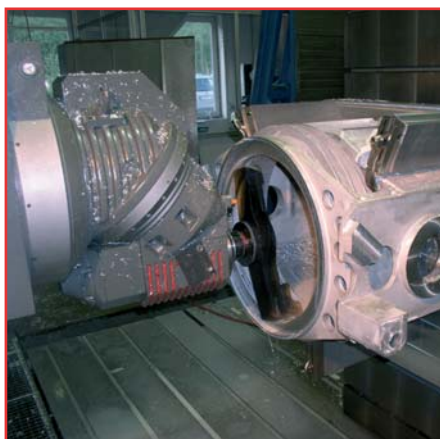
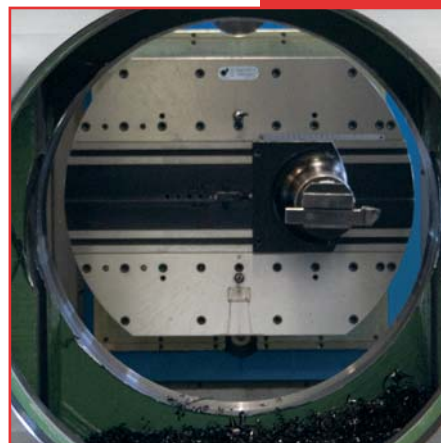

Una tradizione di 70 anni nel settore manifatturiero e una grande passione per la meccanica che oggi è ereditata dalla terza generazione, con l'obiettivo di rispondere alle richieste sempre più esigenti del mondo della meccanica di precisione.

Nella foto qui sopra Ermanno D'Andrea con i figli Amedeo, Maria Pina e Marino.



Golden Compass  
award for industrial design



Lainate (Milano)



Castel Del Giudice (Isernia)

## MHD' Linea



**TS**  
TESTE  
SGROSSATURA

**TRM - TRE**  
TESTAROSSA  
2  $\mu$ m

**TRC**  
TESTAROSSA  
10  $\mu$ m

MHD' 16   MHD' 20   MHD' 25   MHD' 32   MHD' 40   MHD' 50

TS 16/16   TS 20/20   TS 25/25   TS 32/32   TS 40/40   TS 50/50 - 50/63  
 $\varnothing$  18 ~ 22    $\varnothing$  22 ~ 28    $\varnothing$  28 ~ 38    $\varnothing$  35.5 ~ 50    $\varnothing$  50 ~ 68    $\varnothing$  68 ~ 90



TRM 16   TRM 20   TRM 25   TRM 32   TRM 40   TRM 50  $\varnothing$  2.5 ~ 108  
 $\varnothing$  18 ~ 23    $\varnothing$  22 ~ 29    $\varnothing$  28 ~ 38    $\varnothing$  35.5 ~ 51.5    $\varnothing$  48 ~ 63

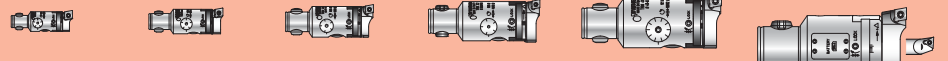

**TRE 50**  $\varnothing$  2.5 ~ 110

TRC 16   TRC 20   TRC 25   TRC 32   TRC 40   TRC 50  $\varnothing$  2.5 ~ 110  
 $\varnothing$  18 ~ 24    $\varnothing$  22 ~ 30    $\varnothing$  28 ~ 40    $\varnothing$  35.5 ~ 53.5    $\varnothing$  48 ~ 66



## PSC Linea

new

**PSC - TS**  
TESTE SGROSSATURA

**PSC - TRM**  
TESTAROSSA 2  $\mu$ m

PSC50 - TS50  
 $\varnothing$  68 ~ 90

PSC 50

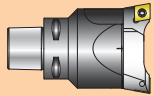

PSC50 - TRM50  
 $\varnothing$  2.5 ~ 108



PSC63 - TS50  
 $\varnothing$  68 ~ 90

PSC63 - TS63  
 $\varnothing$  90 ~ 120

PSC63 - TS80  
 $\varnothing$  120 ~ 200

PSC 63

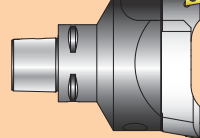
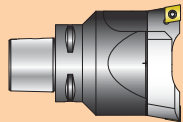
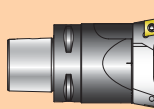

PSC63 - TRM50  
 $\varnothing$  2.5 ~ 108

PSC63 - TRM63  
 $\varnothing$  2.5 ~ 125

PSC63 - TRM80  
 $\varnothing$  2.5 ~ 220

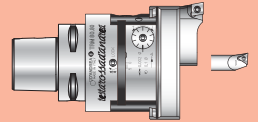
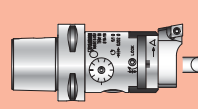

## U-TRONIC

TESTE CN DI  
MEDIE E GRANDI  
DIMENSIONI

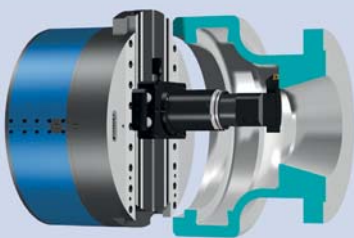

## STANDARD

UT 3-360 S  
 $\varnothing$  max 800

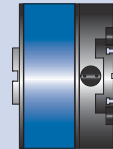

UT 5-500 S  
 $\varnothing$  max 1000

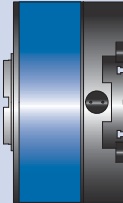

UT 5-630 S  
 $\varnothing$  max 1250

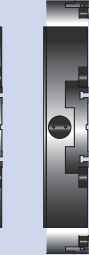

UT 5-800 S  
 $\varnothing$  max 1400



UT 8-800 S  
 $\varnothing$  max 1600

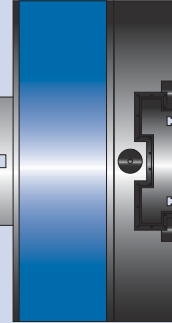

UT 8-1000 S  
 $\varnothing$  max 2000

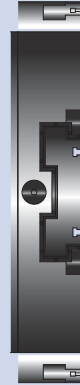

UT 8-1250 S  
 $\varnothing$  max 2700

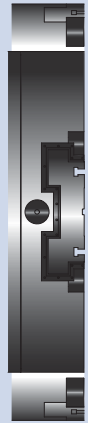

UT 8-1600 S  
 $\varnothing$  max 3200

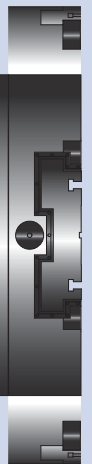

## MONOforce

PORTAUTENSILI DI  
PRECISIONE A  
FORTE SERRAGGIO

DIN 69871



MAS BT



PSC



HSK-A



5  $\mu$ m

$\varnothing$  12 / 20 / 32

MHD' 63

MHD' 80

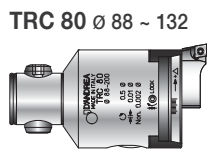
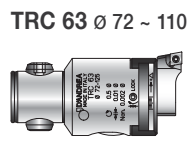
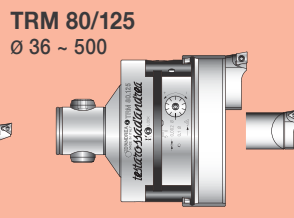
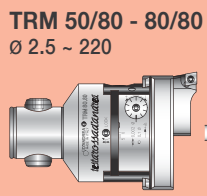
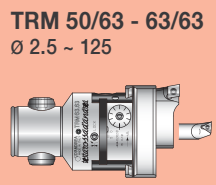
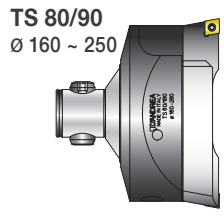
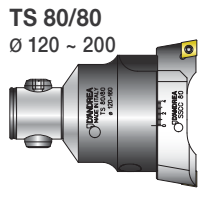
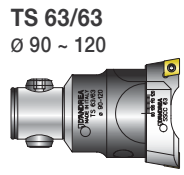

FRESATURA FORATURA



HT Linea **new**

BARRE MODULARI  
ALESATURA - TORNITURA

BHT 250  
Ø 250 ~ 500

BHT 500  
Ø 500 ~ 750



FRESATURA FORATURA



TORNITURA TCD'

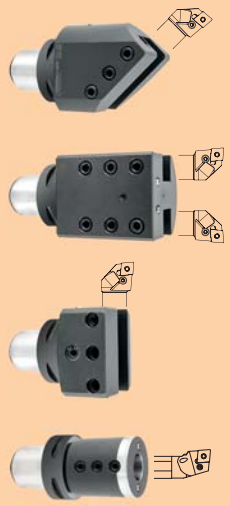

RIDUZIONI

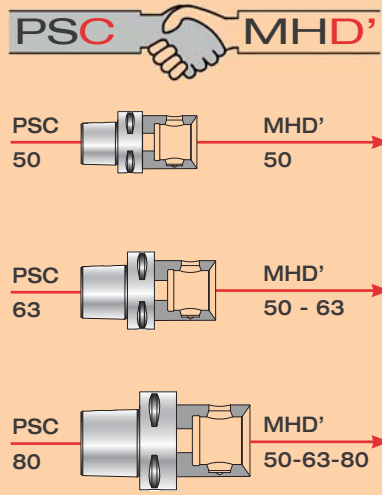

FINITURA 2 µm

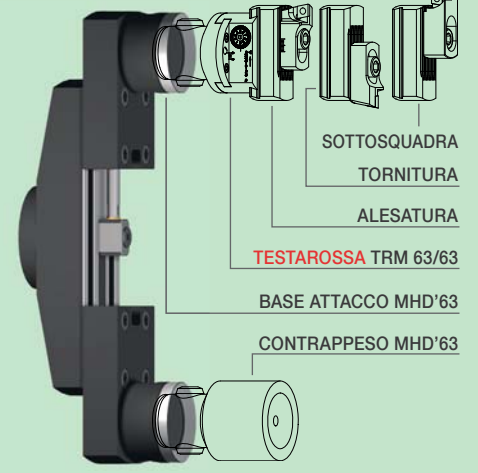

SPECIALI

RIDUTTORE

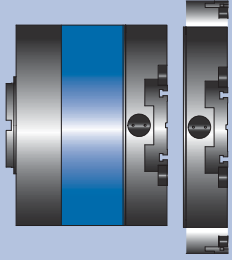

HOLE

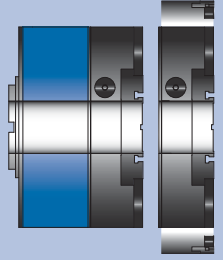

DOPPIA SLITTA

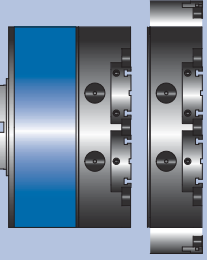

ALTA VELOCITA'

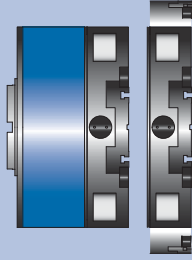

MONOd'  
PORTAUTENSILI  
PORTAPINZE ELASTICHE

DIN 69871



MAS BT



PSC



HSK-A



ER 16 / 25 / 32

*Economio D'Andrea*

# MHD' Linea

È una linea di portautensili modulari di alta precisione che consente di eseguire con estrema flessibilità e rigidità operazioni di alesatura, fresatura, foratura.

L'**attacco MHD'** è il punto di forza del Modulhard'andrea: disponibile in otto grandezze, garantisce l'intercambiabilità di tutti gli elementi del sistema, che include attacchi base, prolunghe, riduzioni e adattatori portautensili.



**MHD'** Linea  
Un ricco **programma di alesatura** con un'ampia gamma di Teste di sgrossatura, **TESTAROSSA** micrometriche e centesimali.

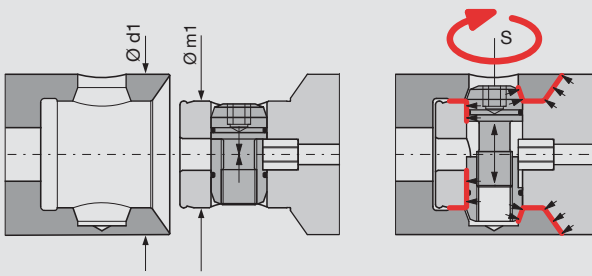

MHD'	Ø d1	Ø m1	⬡ S	N·m
<b>16</b>	16	10	2,5	2 - 2,5
<b>20</b>	20	13	3	4 - 4,5
<b>25</b>	25	16	3	6,5 - 7,5
<b>32</b>	32	20	4	7 - 8
<b>40</b>	40	25	5	16 - 18
<b>50</b>	50	32	6	30 - 35
<b>63</b>	63	42	8	70 - 80
<b>80</b>	80	42	8	70 - 80

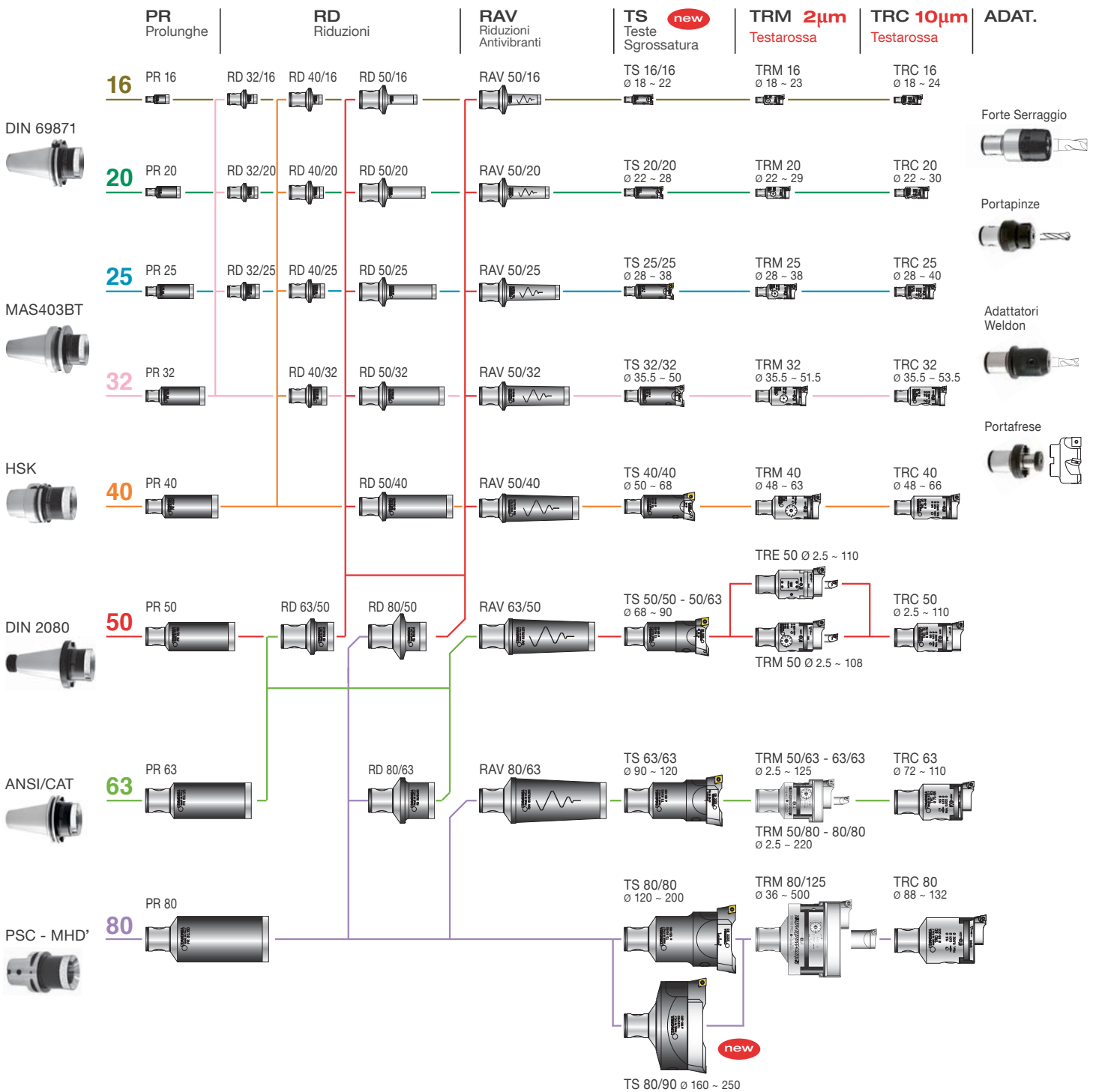



**ATTACCHI BASE** realizzati secondo normative DIN 69871, MAS 403 BT, DIN 69893 e costruiti in acciaio cementato, temprato e rettificato BILANCIATURA 8000 RPM.

## DIN 69871 AD

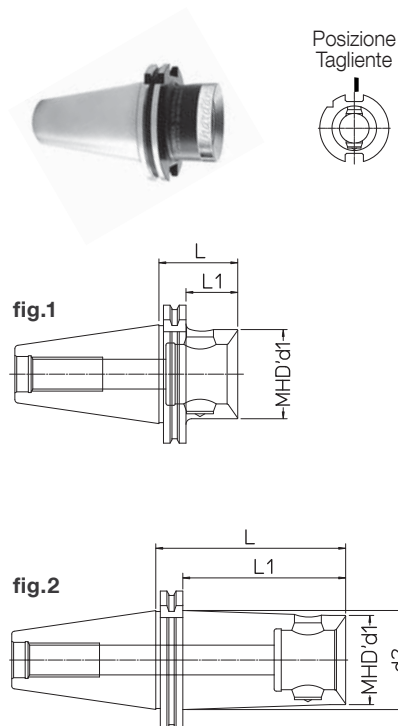

DIN	REF.	CODE	MHD' d1	d2	L	L1	kg	fig.
30	DIN69871-AD30 MHD'50.60	416500103020	50	60	60	0.6	1	
40	DIN69871-AD40 MHD'16.40	416160414020	16	40	21	0.7	1	
40	DIN69871-AD40 MHD'16.63	416160614020	16	17.5	63	44	0.8	2
40	DIN69871-AD40 MHD'16.100	416161014020	16	20	100	81	0.9	2
40	DIN69871-AD40 MHD'20.50	416200514020	20	50	31	0.8	1	
40	DIN69871-AD40 MHD'20.80	416200814020	20	22.5	80	61	0.9	2
40	DIN69871-AD40 MHD'20.125	416201214020	20	25.5	125	106	1	2
40	DIN69871-AD40 MHD'25.50	416250514020	25	50	31	0.9	1	
40	DIN69871-AD40 MHD'25.80	416250814020	25	27	80	61	1	2
40	DIN69871-AD40 MHD'25.125	416251214020	25	30	125	106	1.1	2
40	DIN69871-AD40 MHD'32.50	416320514020	32	50	31	1	1	
40	DIN69871-AD40 MHD'32.80	416320814020	32	33.5	80	61	1.1	2
40	DIN69871-AD40 MHD'32.125	416321214020	32	36.5	125	106	1.2	2
40	DIN69871-AD40 MHD'40.45	416400104020	40	45	26	0.5	1	
40	DIN69871-AD40 MHD'40.120	416401214020	40	44.5	120	101	1.4	2
40	DIN69871-AD40 MHD'50.48	416500104020	50	48	29	0.9	1	
40	DIN69871-AD40 MHD'50.120	416501214020	50	120	101	1.7	1	
40	DIN69871-AD40 MHD'63.80	416630104020	63	80	1.5	1		
50	DIN69871-AD50 MHD'50.48	416500105020	50	48	29	2.5	1	
50	DIN69871-AD50 MHD'50.120	416501215020	50	60	120	101	3.5	2
50	DIN69871-AD50 MHD'63.56	416630105020	63	56	37	2.8	1	
50	DIN69871-AD50 MHD'63.150	416631515020	63	70	150	131	5	2
50	DIN69871-AD50 MHD'80.62	416800105020	80	62	43	3.4	1	
50	DIN69871-AD50 MHD'80.180	416801815020	80	180	161	7.6	1	

Attacchi Versione B - SU RICHIESTA

## DIN 69871 FC AD FACE CONTACT

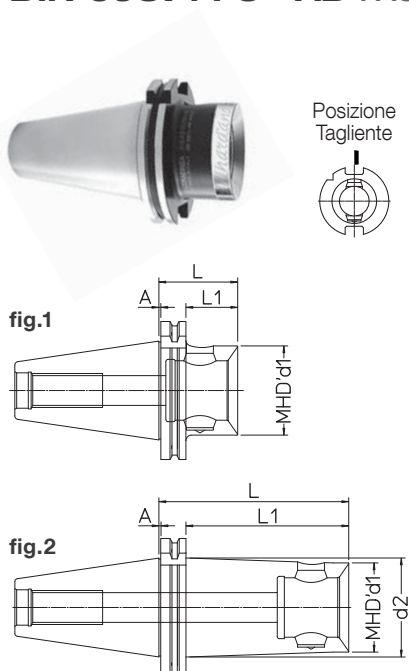

DIN	REF.	CODE	MHD' d1	d2	A	L	L1	kg	fig.
40	DIN69871-AD40 FC MHD'50.48	416500104020F	50	1	48	29	0.9	1	
40	DIN69871-AD40 FC MHD'50.120	416501214020F	50	1	120	101	1.7	1	
40	DIN69871-AD40 FC MHD'63.80	416630104020F	63	1	80	1.5	1		
50	DIN69871-AD50 FC MHD'50.48	416500105020F	50	1.5	48	29	2.5	1	
50	DIN69871-AD50 FC MHD'50.120	416501215020F	50	59	1.5	120	101	3.5	2
50	DIN69871-AD50 FC MHD'50.200	416502015020F	50	68	1.5	200	181	6.1	2
50	DIN69871-AD50 FC MHD'63.56	416630105020F	63	1.5	56	37	2.8	1	
50	DIN69871-AD50 FC MHD'63.150	416631515020F	63	75.5	1.5	150	131	5.2	2
50	DIN69871-AD50 FC MHD'63.250	416632515020F	63	80	1.5	250	231	7.1	2
50	DIN69871-AD50 FC MHD'80.62	416800105020F	80	1.5	62	43	3.4	1	
50	DIN69871-AD50 FC MHD'80.180	416801815020F	80	1.5	180	161	6.9	1	
50	DIN69871-AD50 FC MHD'80.300	416803015020F	80	1.5	300	281	9.2	1	

Attacchi Versione B - SU RICHIESTA

## MAS 403 BT AD

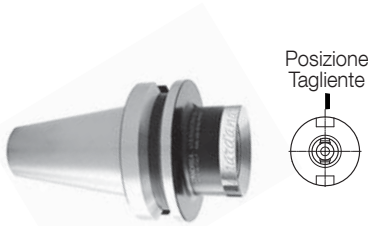

Posizione Tagliente

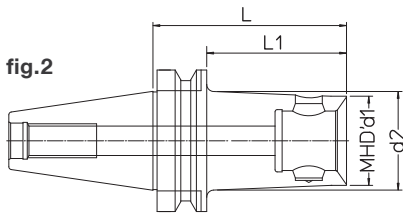
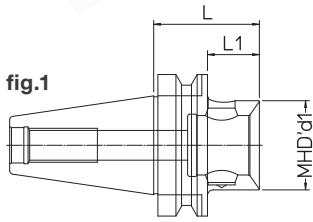

BT	REF.	CODE	MHD' d1	d2	L	L1	kg	fig.
30	MAS403 BT30-AD MHD'50.60	416500103030	50	60		0.7	1	
40	MAS403 BT40-AD MHD'16.45	416160414030	16	45	18	0.8	1	
40	MAS403 BT40-AD MHD'16.63	416160614030	16	17	63	36	0.9	2
40	MAS403 BT40-AD MHD'16.100	416161014030	16	19.5	100	73	1	2
40	MAS403 BT40-AD MHD'20.50	416200514030	20	50	23	0.9	1	
40	MAS403 BT40-AD MHD'20.80	416200814030	20	22	80	53	1	2
40	MAS403 BT40-AD MHD'20.125	416201214030	20	25	125	98	1.1	2
40	MAS403 BT40-AD MHD'25.50	416250514030	25	50	23	1	1	
40	MAS403 BT40-AD MHD'25.80	416250814030	25	26.5	80	53	1.1	2
40	MAS403 BT40-AD MHD'25.125	416251214030	25	29.5	125	98	1.2	2
40	MAS403 BT40-AD MHD'32.50	416320514030	32		23	1.1	1	
40	MAS403 BT40-AD MHD'32.80	416320814030	32	33	80	53	1.2	2
40	MAS403 BT40-AD MHD'32.125	416321214030	32	36	125	98	1.4	2
40	MAS403 BT40 AD MHD'40.45	416400104030	40	45	18	0.6	1	
40	MAS403 BT40-AD MHD'40.120	416401214030	40	44.5	120	93	0.9	2
40	MAS403 BT40-AD MHD'50.48	416500104030	50	48	21	0.9	1	
40	MAS403 BT40-AD MHD'50.120	416501214030	50	120	93	1.9	2	
40	MAS403 BT40-AD MHD'63.66	416630104030	63	66		1.2	1	
50	MAS403 BT50-AD MHD'50.66	416500105030	50	66	28	3.3	1	
50	MAS403 BT50-AD MHD'50.120	416501215030	50	60	120	82	4.2	2
50	MAS403 BT50-AD MHD'63.75	416630105030	63	75	37	3.7	1	
50	MAS403 BT50-AD MHD'63.150	416631515030	63	70	150	112	5.8	2
50	MAS403 BT50-AD MHD'80.75	416800105030	80	75	37	4	1	
50	MAS403 BT50-AD MHD'80.180	416801815030	80	180	142	7.5	2	

Attacchi Versione B - SU RICHIESTA

## MAS 403 BT FC AD FACE CONTACT



Posizione Tagliente

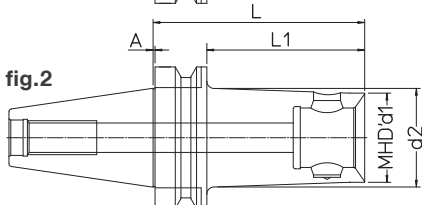
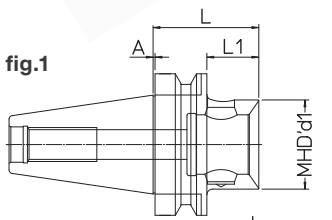

BT	REF.	CODE	MHD' d1	d2	A	L	L1	kg	fig.
40	MAS403 BT40-AD FC MHD'50.48	416500104030F	50	1	48	21	0.9	1	
40	MAS403 BT40-AD FC MHD'50.120	416501214030F	50	1	120	93	1.9	1	
40	MAS403 BT40-AD FC MHD'63.66	416630104030F	63	1	66		1.2	1	
50	MAS403 BT50-AD FC MHD'50.66	416500105030F	50	1.5	66	28	3.2	1	
50	MAS403 BT50-AD FC MHD'50.120	416501215030F	50	57.5	1.5	120	82	4.2	2
50	MAS403 BT50-AD FC MHD'50.200	416502015030F	50	66	1.5	200	162	4.5	2
50	MAS403 BT50-AD FC MHD'63.75	416630105030F	63	1.5	75	37	3.7	1	
50	MAS403 BT50-AD FC MHD'63.150	416631515030F	63	73.5	1.5	150	112	5.8	2
50	MAS403 BT50-AD FC MHD'63.250	416632515030F	63	84	1.5	250	212	6.1	2
50	MAS403 BT50-AD FC MHD'80.75	416800105030F	80	1.5	75	37	4	1	
50	MAS403 BT50-AD FC MHD'80.180	416801815030F	80	1.5	180	142	7.5	1	
50	MAS403 BT50-AD FC MHD'80.300	416803015030F	80	1.5	300	262	9.2	1	

Attacchi Versione B - SU RICHIESTA

**ATTACCHI BASE** realizzati secondo normative DIN 69871, MAS 403 BT, DIN 69893, DIN 2080 e costruiti in acciaio cementato, temprato e rettificato BILANCIATURA 8000 RPM.

## DIN 69893 HSK-A

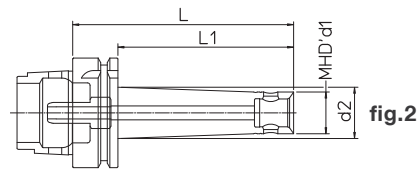
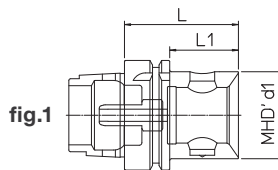

Completo di raccordo per il refrigerante

HSK-A	REF.	CODE	MHD' d1	d2	L	L1	kg	fig.
50	HSK-A50 MHD'50.66	416501505020	50		66		0.6	1
63	HSK-A63 MHD'16.100	416161056320	16	19.5	100	74	0.8	2
63	HSK-A63 MHD'20.125	416201256320	20	25	125	99	0.9	2
63	HSK-A63 MHD'25.125	416251256320	25	29.5	125	99	1	2
63	HSK-A63 MHD'32.90	416320956320	32	33.5	90	64	1	2
63	HSK-A63 MHD'32.125	416321256320	32	36	125	99	1.2	2
63	HSK-A63 MHD'40.60	416401506320	40		60	34	0.7	1
63	HSK-A63 MHD'40.120	416401506328	40	46	120	94	1.4	2
63	HSK-A63 MHD'50.66	416501506320	50		66	40	0.9	1
63	HSK-A63 MHD'50.120	416501506328	50		120	94	1.7	1
63	HSK-A63 MHD'63.75	416631506320	63		75		1.1	1
80	HSK-A80 MHD'50.70	416501508020	50		70	44	1.5	1
80	HSK-A80 MHD'63.80	416631508020	63		80	54	1.8	1
100	HSK-A100 MHD'50.72	416501510020	50		72	43	2.4	1
100	HSK-A100 MHD'63.82	416631510020	63		82	53	2.7	1
100	HSK-A100 MHD'50.120	416501510028	50	60	120	91	3.2	2
100	HSK-A100 MHD'80.88	416801510020	80		88	59	3	1
100	HSK-A100 MHD'63.150	416631510028	63	70	150	121	4.5	2
100	HSK-A100 MHD'80.180	416801510028	80		180	151	6.5	1

## DIN 2080-A 'OTT'

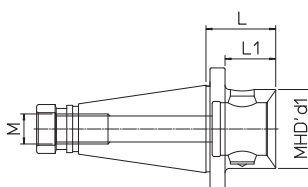

DIN	REF.	CODE	MHD' d1	L	L1	M	kg
30	DIN2080-A30 MHD'50.58	416500103000	50	58		M12	0.6
40	DIN2080-A40 MHD'50.48	416500104000	50	48	36.5	M16	0.9
40	DIN2080-A40 MHD'63.60	416630104000	63	60		M16	1.2
50	DIN2080-A50 MHD'50.48	416500105000	50	48	33	M24	2.6
50	DIN2080-A50 MHD'63.56	416630105000	63	56	41	M24	2.7
50	DIN2080-A50 MHD'80.60	416800105000	80	60	45	M24	3.2

## ANSI/CAT AD

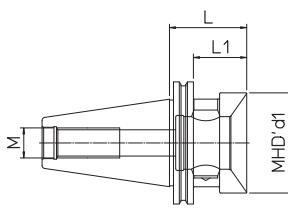

ANSI/CAT	REF.	CODE	MHD' d1	L	L1	M	kg
40	ANSI/CAT40 MHD'50.66	416500104040	50	66	47	M16	1.1
40	ANSI/CAT40 MHD'63.100	416630104040	63	100		M16	1.9
50	ANSI/CAT50 MHD'50.48	416500105040	50	48	29	M24	2.4
50	ANSI/CAT50 MHD'63.56	416630105040	63	56	37	M24	2.9
50	ANSI/CAT50 MHD'80.62	416800105040	80	62	43	M24	3.2

## BR BARRE IN ACCIAIO

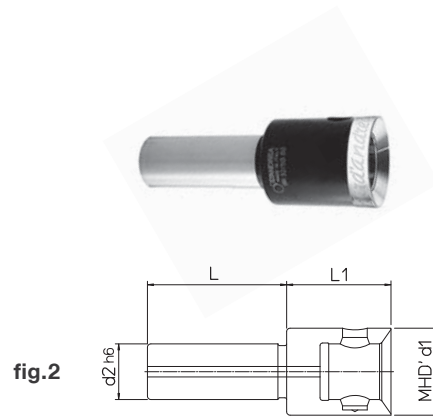
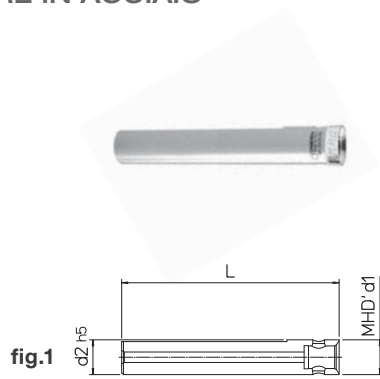

REF.	CODE	MHD' d1	L	L1	d2	kg	fig.
BR 16/16.100	657081601001	16	100		16	0.15	1
BR 20/20.125	657082001251	20	125		20	0.3	1
BR 25/32.35	416320802500	32	65	35	25	0.7	2
BR 32/50.60	416500803200	50	80	60	32	1	2

## BMD BARRE IN METALLO DURO

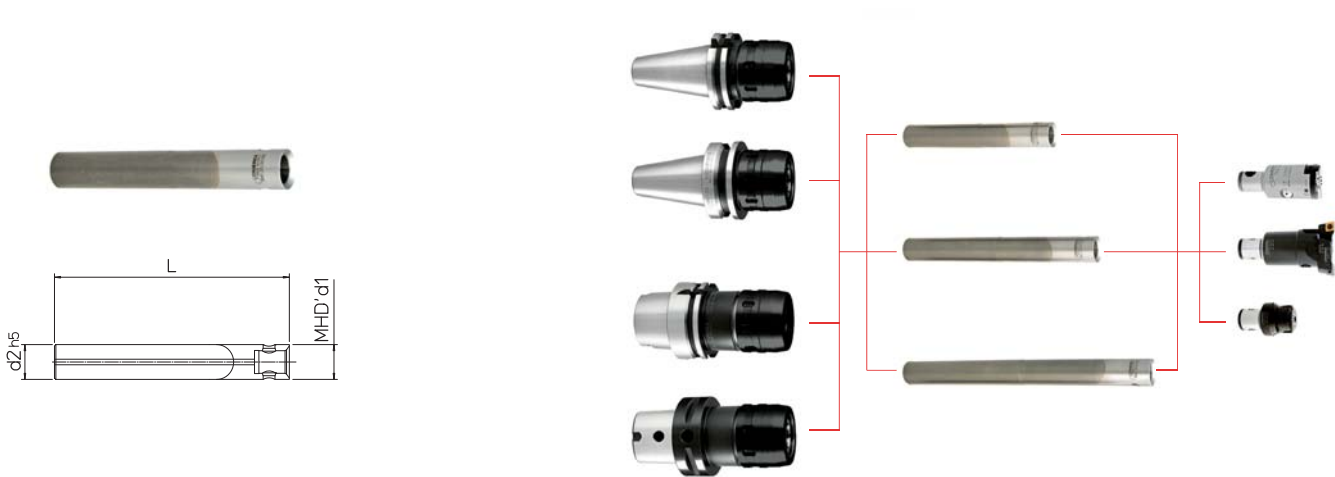

REF.	CODE	MHD' d1	d2	L	kg
BMD 16/16.110	657081601105	16	16	110	0.3
BMD 16/16.140	657081601405	16	16	140	0.4
BMD 16/16.170	657081601705	16	16	170	0.5
BMD 20/20.135	657082001355	20	20	135	0.6
BMD 20/20.170	657082001705	20	20	170	0.75
BMD 20/20.210	657082002105	20	20	210	0.9
BMD 25/25.160	657082501605	25	25	160	1
BMD 25/25.205	657082502055	25	25	205	1.3
BMD 25/25.255	657082502555	25	25	255	1.6
BMD 32/32.195	657083201955	32	32	195	2.1
BMD 32/32.250	657083202505	32	32	250	2.8
BMD 32/32.315	657083203155	32	32	315	3.5

### PR PROLUNGHE

Per ogni grandezza MHD' esistono prolunghe di diverse lunghezze che consentono di raggiungere le profondità di lavorazione desiderate.

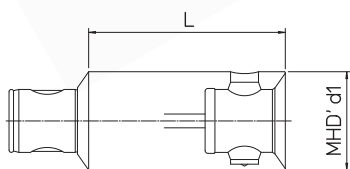

REF.	CODE	MHD' d1	L	kg
PR 16.25	656901600250	16	25	0.04
PR 20.32	656902000320	20	32	0.07
PR 25.25	656902500250	25	25	0.09
PR 25.40	656902500400	25	40	0.15
PR 32.32	656903200320	32	32	0.2
PR 32.50	656903200500	32	50	0.3
PR 40.40	656904000400	40	40	0.4
PR 40.63	656904000630	40	63	0.6
PR 50.50	656905000500	50	50	0.7
PR 50.80	656905000800	50	80	1.1
PR 50.100	656905001000	50	100	1.5
PR 63.63	656906300630	63	63	1.4
PR 63.100	656906301000	63	100	2.2
PR 63.125	656906301250	63	125	2.9
PR 80.80	656908000800	80	80	3
PR 80.125	656908001250	80	125	4.6
PR 80.160	656908001600	80	160	6.1

### RD RIDUZIONI

Le riduzioni permettono di utilizzare componenti MHD' di una grandezza più piccola e quindi ottimizzare la composizione dell'utensile in funzione degli ingombri.

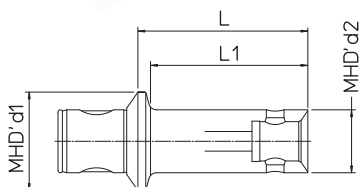

REF.	CODE	MHD' d1	MHD' d2	L	L1	kg
RD 20/16.20	657002000160	20	16	20	16	0.05
RD 25/16.20	657002500160	25	16	20	15	0.07
RD 25/20.25	657002500200	25	20	25	20	0.08
RD 32/16.24	657003200160	32	16	24	18	0.10
RD 32/20.25	657003200200	32	20	25	20	0.12
RD 32/25.28	657003200250	32	25	28	23	0.14
RD 40/16.24	657004000160	40	16	24	17	0.18
RD 40/20.26	657004000200	40	20	26	20	0.2
RD 40/25.28	657004000250	40	25	28	22	0.25
RD 40/32.32	657004000320	40	32	32	27	0.3
RD 50/16.24	657005000160	50	16	24	15	0.34
RD 50/16.40	657005000162	50	16	40	32	0.2
RD 50/16.74	657005000163	50	16	74	65	0.25
RD 50/20.26	657005000200	50	20	26	18	0.37
RD 50/20.70	657005000202	50	20	70	62	0.3
RD 50/20.93	657005000203	50	20	93	85	0.35
RD 50/25.28	657005000250	50	25	28	21	0.4
RD 50/25.87	657005000252	50	25	87	80	0.6
RD 50/25.117	657005000253	50	25	117	110	0.65
RD 50/32.32	657005000320	50	32	32	25	0.45
RD 50/32.87	657005000322	50	32	87	80	0.75
RD 50/32.144	657005000323	50	32	144	137	1
RD 50/40.36	657005000400	50	40	36	30	0.5
RD 50/40.87	657005000402	50	40	87	80	0.9
RD 50/40.176	657005000403	50	40	176	170	1.8
RD 63/50.40	657006300500	63	50	40	34	0.9
RD 80/50.45	657008000500	80	50	45	36	1.2
RD 80/63.60	657008000630	80	63	60	52	1.7

### RAV ANTIVIBRANTI

Riduzioni antivibranti per lavorazioni profonde o gravose.

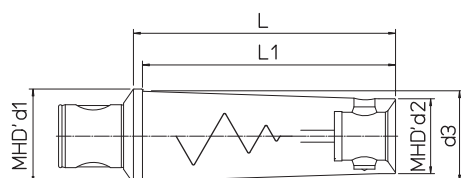

REF.	CODE	MHD' d1	MHD' d2	d3	L	L1	kg
RAV 50/16.74	657005000165	50	16	17.5	74	65	0.4
RAV 50/20.93	657005000205	50	20	21.5	93	85	0.5
RAV 50/25.117	657005000255	50	25	27	117	110	0.8
RAV 50/32.144	657005000325	50	32	35	144	138	1.4
RAV 50/40.176	657005000405	50	40	47	176	170	2.5
RAV 63/50.220	657006300505	63	50	60	220	214	5.6
RAV 80/63.280	657008000635	80	63	77	280	272	10.6

*TS teste sgrossatura*

*teste sgrossatura*



# MHD' Linea

**TS 16 ~ 80**  $\varnothing 18 \sim 250$

Teste di sgrossatura semplici ed estremamente rigide grazie alle superfici di contatto dentellate tra il corpo testa e i seggi portainserito. La distanza costante tra la vite di serraggio del seggio ed il tagliante garantisce la stabilità del sistema.



1. Corpo
2. Vite di regolazione
3. Perno radiale espandibile
4. Fori uscita refrigerante  
**Max BAR 40**
5. Seggio portainseri
6. Viti bloccaggio utensile

**TS 16/16**  $\varnothing 18 \sim 22$

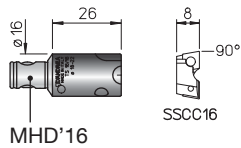

**TS 40/40**  $\varnothing 50 \sim 68$

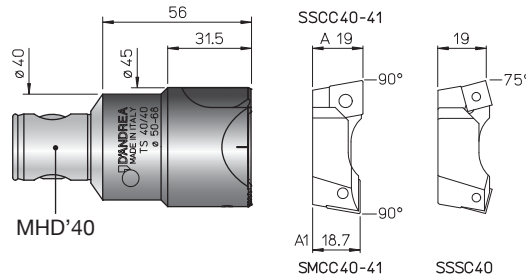

**TS 20/20**  $\varnothing 22 \sim 28$

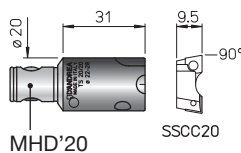

**TS 50/50**  $\varnothing 68 \sim 90$

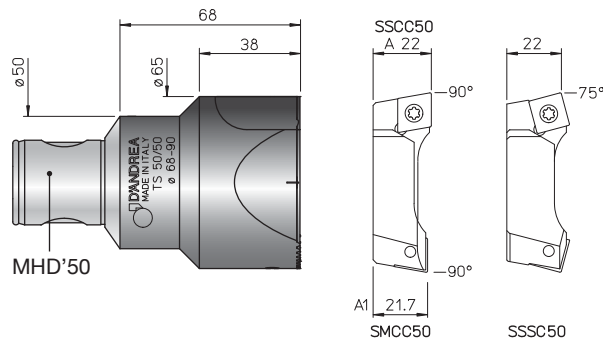

**TS 25/25**  $\varnothing 28 \sim 38$

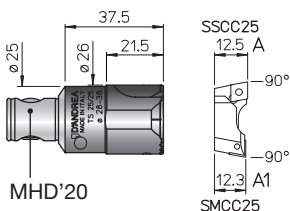

**TS 50/63 - TS 63/63**  $\varnothing 90 \sim 120$

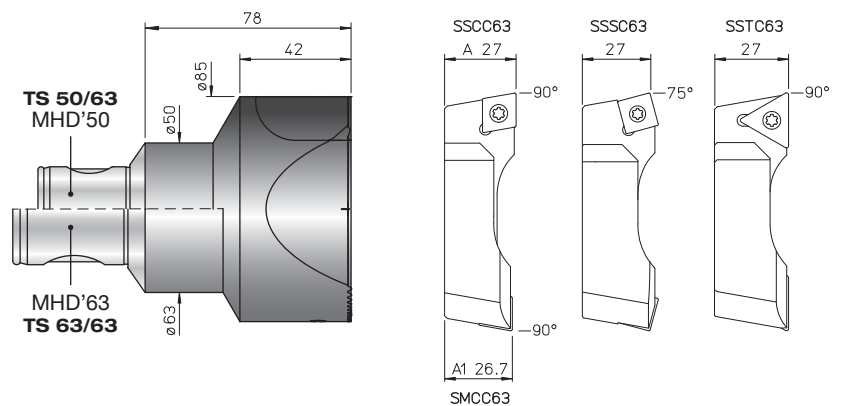

**TS 32/32**  $\varnothing 35.5 \sim 50$

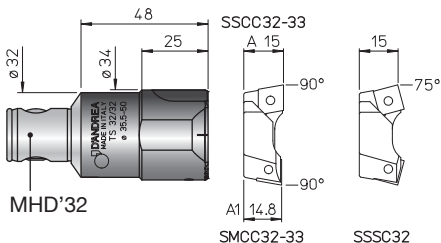

REF.	CODE	kg		
TS 16/16	455501600340	0.05		
TS 20/20	455502000400	0.09		
TS 25/25 <b>new</b>	455502500510	0.2		
TS 32/32 <b>new</b>	455503232638	0.35		
TS 40/40 <b>new</b>	455504040070	0.7		

REF.	CODE	kg		
TS 50/50 <b>new</b>	455505050090	1.5		
TS 50/63 <b>new</b>	455505063100	2		
TS 63/63 <b>new</b>	455506363100	3		
TS 80/80 <b>new</b>	455508080110	5.3		
TS 80/90 <b>new</b>	455508090090	6.3		

TS 80/80 Ø 120 ~ 200

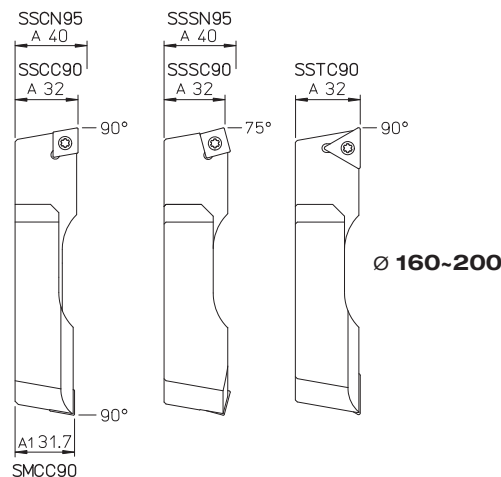
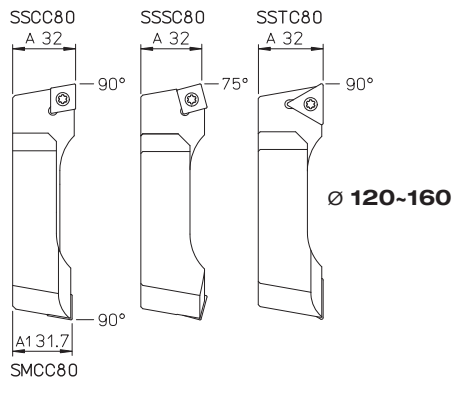
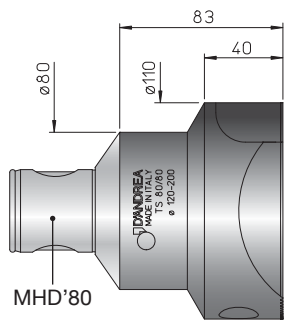

TS 80/90 Ø 160 ~ 250

new

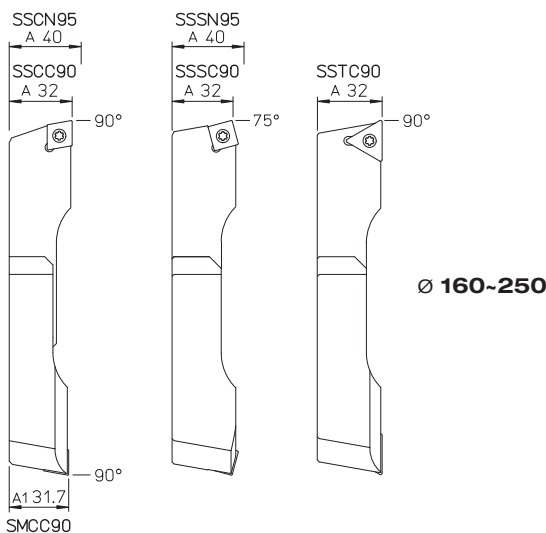
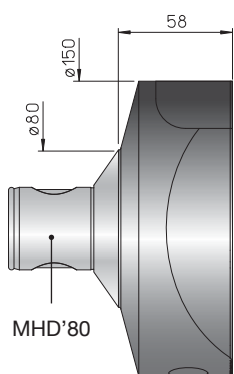

IMPIEGO TS per operazioni di SGROSSATURA e SEMI-FINITURA

La regolazione dei taglienti va eseguita su un banco di presetting e le testine TS possono essere utilizzate in tre diverse configurazioni. Per lavorare con un solo tagliente o con differenti diametri di taglio, dimezzare l'avanzamento.

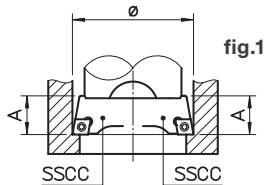

fig.1 con due seggi SSCC allineati e sullo stesso diametro per operazioni di sgrossatura con forti avanzamenti.

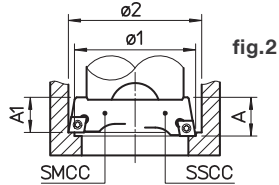

fig. 2 con un seggio SSCC ed un seggio SMCC disallineato e su un diverso diametro per operazioni di sgrossatura con alte profondità di passata.

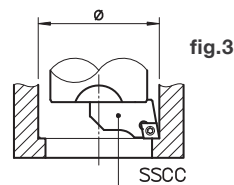

fig.3 con un solo seggio per operazioni di sgrossatura leggera o semifinitura.

REF.	CODE	TS TORX T	kg
SSCC 16	470500516201	CCMT 0602..	25 08 0.003
SSCC 20	470500520201	CCMT 0602..	25 08 0.006
SSCC 25	470500525201	CCMT 0602..	25 08 0.1
SSCC 32	470500532201	CCMT 0602..	25 08 0.02
SSCC 33	470500532204	CCMT 09T3..	4 15 0.025
SSCC 40	470500540201	CCMT 09T3..	4 15 0.06
SSCC 41	470500540204	CCMT 1204..	5 25 0.06
SSCC 50	470500550204	CCMT 1204..	5 25 0.1
SSCC 63	470500563201	CCMT 1204..	5 25 0.2
SSCC 80	470500580201	CCMT 1204..	5 25 0.5
SSCC 90	470500590201	CCMT 1204..	5 25 0.7
SSCN 95	470500595201	CNM. 1906..	0.9
SSTC 63	470500563206	TCMT 2204..	5 25 0.2
SSTC 80	470500580206	TCMT 2204..	5 25 0.5
SSTC 90	470500590206	TCMT 2204..	5 25 0.7

REF.	CODE	TS TORX T	kg
SMCC 25	470500525203	CCMT 0602..	25 08 0.01
SMCC 32	470500532203	CCMT 0602..	25 08 0.02
SMCC 33	470500532205	CCMT 09T3..	4 15 0.025
SMCC 40	470500540203	CCMT 09T3..	4 15 0.06
SMCC 41	470500540205	CCMT 1204..	5 25 0.06
SMCC 50	470500550205	CCMT 1204..	5 25 0.1
SMCC 63	470500563203	CCMT 1204..	5 25 0.2
SMCC 80	470500580203	CCMT 1204..	5 25 0.5
SMCC 90	470500590203	CCMT 1204..	25 08 0.7
SSSC 32	470500532202	SCMT 09T3..	4 15 0.02
SSSC 40	470500540202	SCMT 09T3..	4 15 0.06
SSSC 50	470500550202	SCMT 1204..	5 25 0.1
SSSC 63	470500563202	SCMT 1204..	5 25 0.2
SSSC 80	470500580202	SCMT 1204..	5 25 0.5
SSSC 90	470500590202	SCMT 1204..	5 25 0.7
SSSN 95	470500595202	SNM. 1906..	0.9

• Per lavorazioni SOTTOSQUADRA vedere p.26



*testarossa d'andrea*

*testa*

testatoga

testatoga



## TRM 16 ~ 125 Ø 2.5 ~ 500

TRM 16 - 20 RPM 12.000 TRM 63 RPM 6.000  
 TRM 25 - 32 RPM 10.000 TRM 80 RPM 5.000  
 TRM 40 - 50 RPM 8.000 TRM 125 RPM 4.000

Le testine **TRM** consentono lavorazioni di alta precisione e ottima finitura superficiale in tolleranze di grado **IT6**. La sensibilità di regolazione di **1 micron** sul raggio è facilmente leggibile sul nonio ed eseguibile anche in macchina.

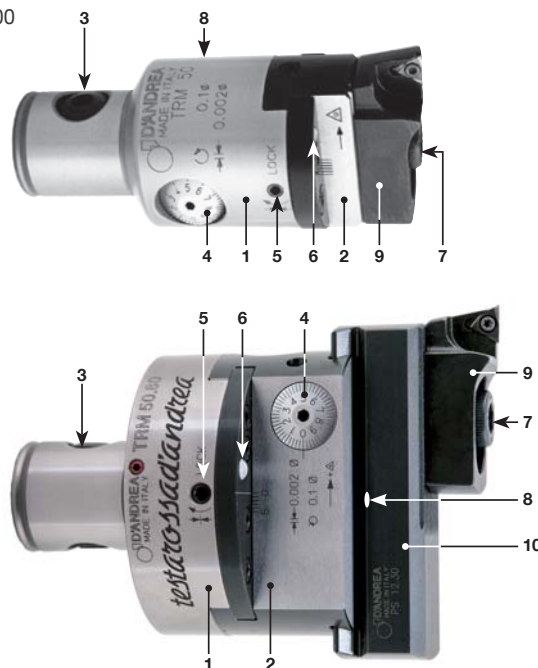

1. Corpo
2. Slitta portautensili
3. Perno radiale espandibile
4. Nonio micrometrico
5. Vite bloccaggio slitta
6. Uscita refrigerante Max BAR 40
7. Viti bloccaggio utensili
8. Oliatore
9. Seggio portainserti
10. Porta utensile

## TESTE MICROMETRICHE

**2 µm**

## TRE 50 IP69K Ø 2.5 ~ 110

TRE 50 69K RPM 20.000

La testina **TRE 50** consente lavorazioni di alta precisione e ottima finitura superficiale in tolleranze di grado **IT6**. La sensibilità di regolazione di **1 micron** sul raggio è veloce e precisa, facilmente visualizzabile sul display integrato. La **TRE 50** è resistente alle infiltrazioni secondo il grado **IP69K**.

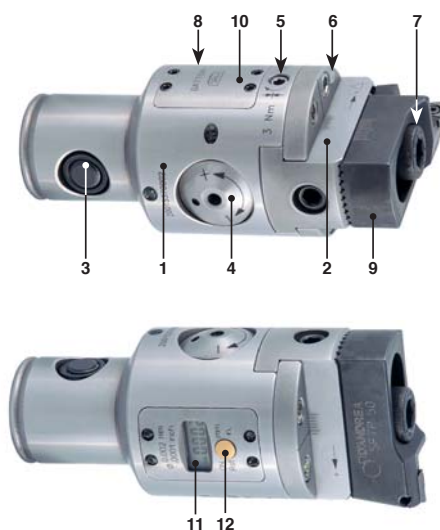

1. Corpo
2. Slitta portautensili
3. Perno radiale espandibile
4. Vite di regolazione
5. Vite bloccaggio slitta
6. Ugello uscita refrigerante Max BAR 40
7. Vite bloccaggio utensili
8. Oliatore
9. Seggio portainserti
10. Coperchio vano pile
11. Display digitale
12. Pulsante di selezione

## TESTA MICROMETRICA DIGITALE

**2 µm**

## TRC 16 ~ 80 Ø 18 ~ 132

TRC 25 - 32 RPM 10.000 TRC 63 RPM 6.000  
 TRC 40 - 50 RPM 8.000 TRC 80 RPM 5.000

Le testine **TRC** consentono lavorazioni di alta precisione e ottima finitura superficiale in tolleranze di grado **IT7**. La sensibilità di regolazione di **5 micron** sul raggio è facilmente leggibile sul nonio ed eseguibile anche in macchina.



**10 µm**  
 nonio vernier 2 µm

1. Corpo
2. Slitta portautensili
3. Perno radiale espandibile
4. Nonio
5. Vite bloccaggio slitta
6. Uscita refrigerante Max BAR 40
7. Viti bloccaggio utensile
8. Oliatore
9. Seggio portainserti

## TESTE CENTESIMALI

# TRM 16 ~ 40 MICROMETRICHE **TESTAROSSA**

## TRM 16 Ø 18 ~ 23

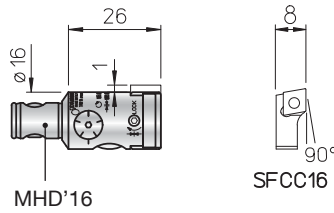

## TRM 20 Ø 22 ~ 29

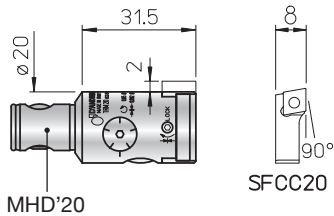

## TRM 25 Ø 28 ~ 38

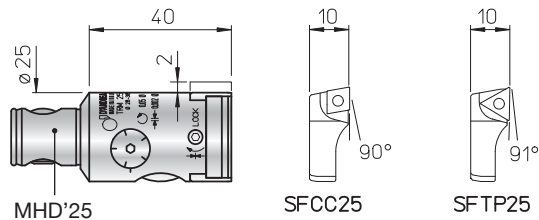

## TRM 32 Ø 35.5 ~ 51.5

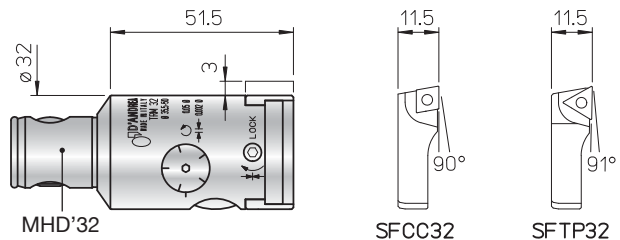

## TRM 40 Ø 48 ~ 63

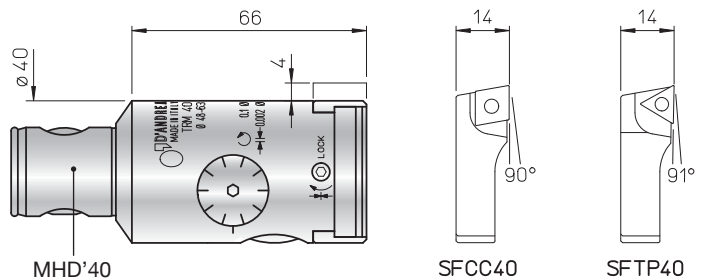

REF.	CODE	kg		
TRM 16	455001600341	0.05		
TRM 20	455002000401	0.1		
TRM 25	455002500500	0.2		
TRM 32	455003200630	0.35		
TRM 40	455004000800	0.7		

REF.	CODE		TORX T	kg		
SFCC 16	470500516002	CCGT 0602..	TS 25	08	0.003	
SFCC 20	470500520002	CCGT 0602..	TS 25	08	0.005	
SFCC 25	470500525002	CCGT 0602..	TS 25	08	0.01	
SFCC 32	470500532002	CCGT 0602..	TS 25	08	0.02	
SFCC 40	470500540002	CCGT 09T3..	TS 4	15	0.04	
SFTP 25	470500525001	TPGX 0902..	CS 250T	08	0.01	
SFTP 32	470500532001	TPGX 0902..	CS 250T	08	0.02	
SFTP 40	470500540001	TPGX 1103..	CS 300890T	08	0.04	

• Per lavorazioni SOTTOSQUADRA vedere p.26

**TRM 50** Ø 2.5 ~ 108

**TRE 50 IP69K** Ø 2.5 ~ 110



**2 μm**

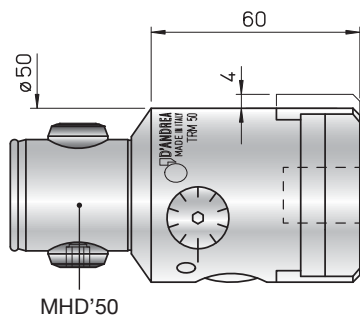

**TRM 50**  
Ø 2.5-108

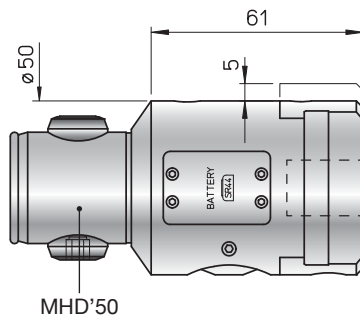

**TRE 50 IP69K**  
Ø 2.5-110

**Utensili**

**Uten. antivibranti**

**Utensili metallo duro**

RDC D08.16

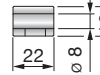

B1.02 Ø2,5-4 B1.04 Ø4-6

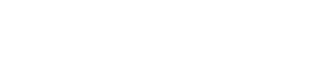
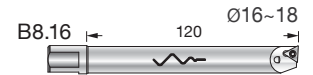
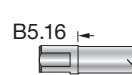
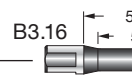
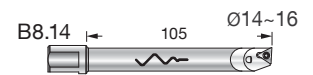
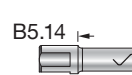
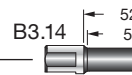
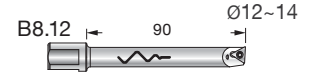
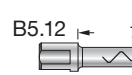
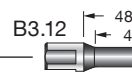
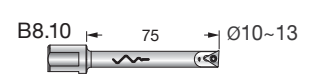
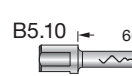
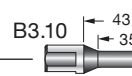
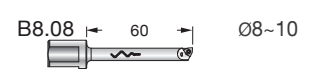
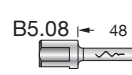
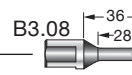
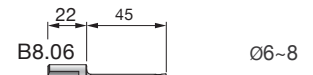
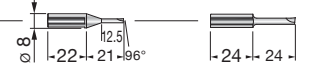

Ø 28-44  
TRM50 Ø 28-42  
TRE50 Ø 28-44

Ø 36-56  
TRM50 Ø 36-54  
TRE50 Ø 36-56

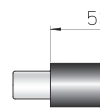

P 25.63

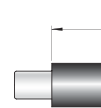

P 25.105

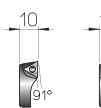

SFTP25

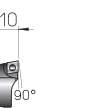

SFCC25

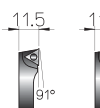

SFTP32

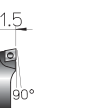

SFCC32

REF.	CODE	kg
TRM 50	455005000500	1
TRE 50 IP69K	455200500501	1.1
D08.16	200560116082	0.02
P25.63	435116250631	0.5
P25.105	435116251051	0.8
PS 31.24	433024140751	0.19
CW 32	392011003201	0.07

Ø 54-86  
TRM50 Ø 54-84  
TRE50 Ø 54-86

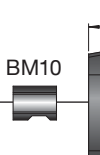

BM10

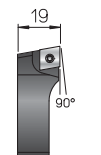

SFTP50

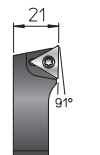

SFCC50

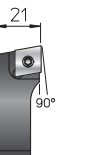

SFTP51

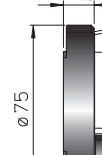

SFCC51

Ø 80-110  
TRM50 Ø 80-108  
TRE50 Ø 80-110

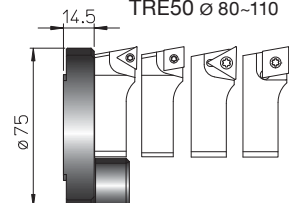

PS31.24 CW32

## KIT K01 TRM 50 Ø 6 ~ 108



- 1 TRM 50**
- 1 B3.06
- 1 B3.08
- 1 B3.11
- 1 B3.16
- 1 B3.22
- 1 SFTP 25
- 1 SFTP 32
- 1 SFTP 50
- 1 P 25.63
- 1 PS 31.24
- 1 CW 32
- 5 TPGX 090202L DC100
- 1 TPGX 110302L DC100
- 2 WCGT 020102L DC10

REF.	CODE	kg
KIT K01 TRM 50	655005010501	3.1

## KIT K01 TRE 50 IP69K Ø 6 ~ 110



- 1 TRE 50**
- 1 B3.06
- 1 B3.08
- 1 B3.11
- 1 B3.16
- 1 B3.22
- 1 SFTP 25
- 1 SFTP 32
- 1 SFTP 50
- 1 P 25.63
- 1 PS 31.24
- 1 CW 32
- 5 TPGX 090202L DC100
- 1 TPGX 110302L DC100
- 2 WCGT 020102L DC10

REF.	CODE	kg
KIT K01 TRE 50 IP69K	655200500502	3.1

### KIT K01 TRM 50 - TRE 50 IP69K

### Campo di Lavoro

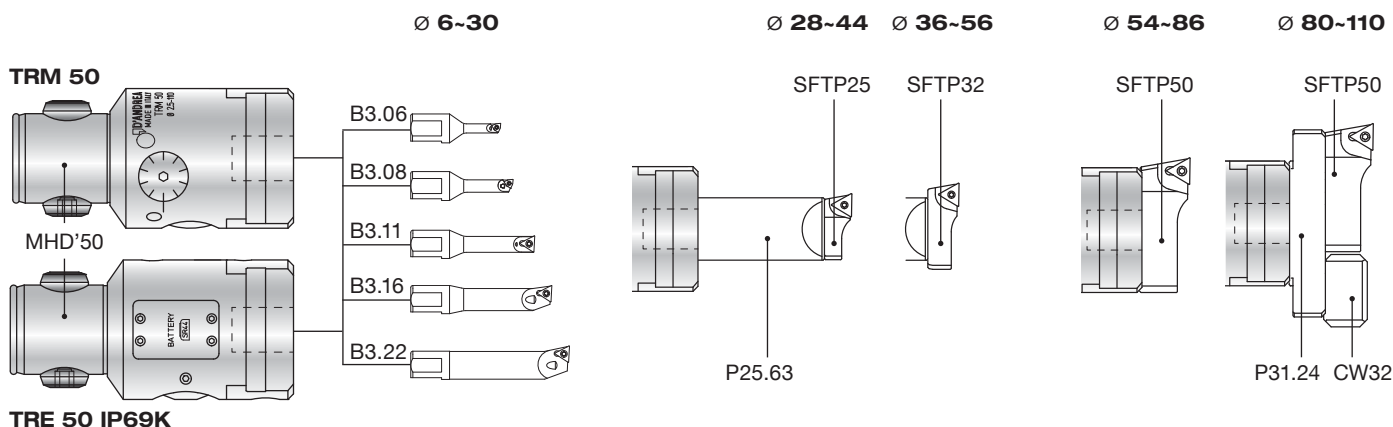

REF.	CODE	TORX T	kg
B1.02	572010502001		0.02
B1.04	572010504001		0.02
B3.06	572010506001	WCGT0201.. TS 21 06	0.035
B3.08	572010508001	WCGT0201.. TS 211 06	0.4
B3.10	572010510001	TPGX0902.. CS 250 T 08	0.05
B3.11	572010511001	TPGX0902.. CS 250 T 08	0.055
B3.12	572010512001	TPGX0902.. CS 250 T 08	0.06
B3.14	572010514001	TPGX0902.. CS 250 T 08	0.07
B3.16	572010516001	TPGX0902.. CS 250 T 08	0.07
B3.18	572010518001	TPGX0902.. CS 250 T 08	0.1
B3.22	572010522001	TPGX0902.. CS 250 T 08	0.1

REF.	CODE	TORX T	kg
B5.06	572010506105	WCGT0201.. TS 21 06	0.075
B5.08	572010508105	WCGT0201.. TS 211 06	0.09
B5.10	572010510105	TPGX0902.. CS 250 T 08	0.1
B5.12	572010512105	TPGX0902.. CS 250 T 08	0.1
B5.14	572010514105	TPGX0902.. CS 250 T 08	0.2
B5.16	572010516105	TPGX0902.. CS 250 T 08	0.3
B8.06	572010506108	WCGT0201.. TS 21 06	0.065
B8.08	572010508108	WCGT0201.. TS 211 06	0.08
B8.10	572010510108	TPGX0902.. CS 250 T 08	0.1
B8.12	572010512108	TPGX0902.. CS 250 T 08	0.2
B8.14	572010514108	TPGX0902.. CS 250 T 08	0.2
B8.16	572010516108	TPGX0902.. CS 250 T 08	0.3

REF.	CODE	TORX T	kg
SFTP25	470500525001	TPGX0902.. CS 250T 08	0.01
SFTP32	470500532001	TPGX0902.. CS 250T 08	0.02
SFTP50	470500550001	TPGX1103.. CS300890T 08	0.08
SFTP51	470500550003	TCMT16T3.. TS 4 15	0.09

REF.	CODE	TORX T	kg
SFCC25	470500525002	CCGT0602.. TS 25 08	0.01
SFCC32	470500532002	CCGT0602.. TS 25 08	0.02
SFCC50	470500550002	CCGT09T3.. TS 4 15	0.08
SFCC51	470500550004	CCMT1204.. TS 5 25	0.09

• Per lavorazioni SOTTOSQUADRA vedere p.26

## TRM 50/63 - TRM 63/63

Ø 2.5 ~ 125



## TRM 50/80 - TRM 80/80

Ø 2.5 ~ 220



2 μm

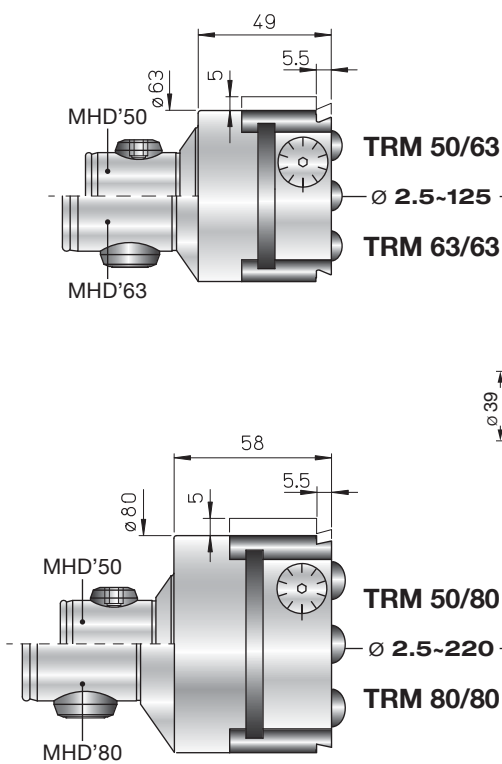

### Utensili

RDC D08.16

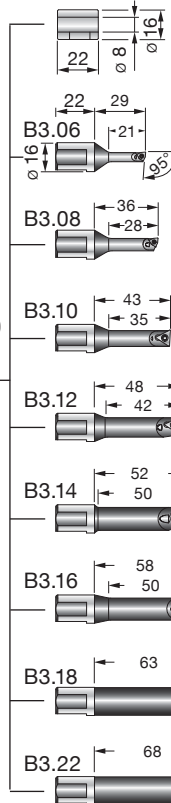

### Uten. antivibranti

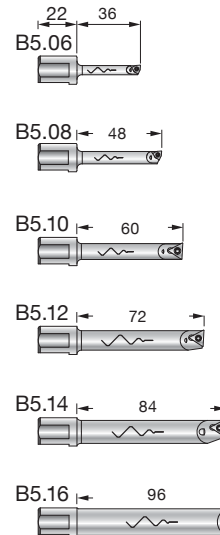

### Utensili metallo duro

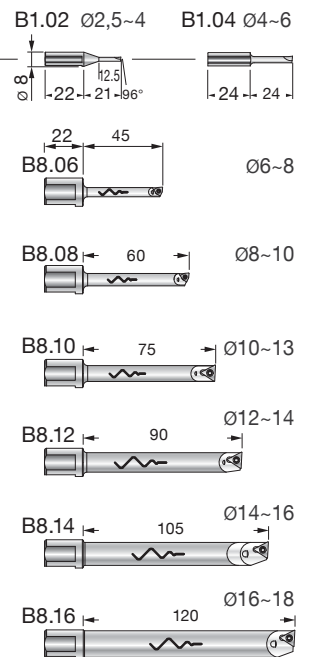

REF.	CODE	kg
TRM 50/63	455005000631	1.1
TRM 63/63	455006300631	1.5
TRM 50/80	455005000801	2
TRM 80/80	455008000801	2.5
D08.16	200560116082	0.02
P20.30	431030160300	0.2
P02.30	431030250400	0.3
P03.30	431030250700	0.4
P04.30	431030251150	0.7
PS 11.30	433030260750	0.4
PS 12.30	433030260950	0.5
PS 13.30	433030261400	0.7

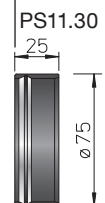
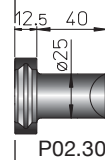

TRM63  
Ø 77-100

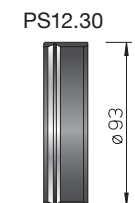
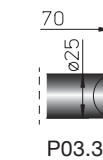

TRM63 - TRM80  
Ø 95-125 - Ø 95-140

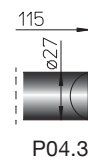

TRM80  
Ø 140-220

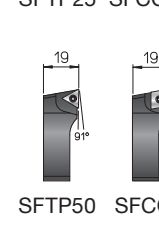
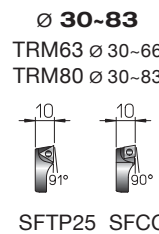

Ø 77-220

## KIT K01 TRM 50/63 - 63/63

Ø 6 ~ 125



### 1 TRM 50/63 - 63/63

- 1 P20.30      1 B3.11
- 1 PS11.30    1 B3.16
- 1 P02.30      1 B3.22
- 1 P03.30      1 SFTP25
- 1 B3.06       1 SFTP32
- 1 B3.08       1 SFTP50

- 5 TPGX 090202L DC100
- 1 TPGX 110302L DC100
- 2 WCGT 020102L DC 10

REF.	CODE	kg
KIT K01 TRM50/63	655005010632	3.9
KIT K01 TRM63/63	655006310632	4.2

## KIT K01 TRM 50/80 - 80/80

Ø 6 ~ 220



### 1 TRM 50/80 - 80/80

- 1 P20.30      1 B3.08
- 1 PS12.30    1 B3.11
- 1 PS13.30    1 B3.16
- 1 P02.30      1 B3.22
- 1 P03.30      1 SFTP25
- 1 P04.30      1 SFTP32
- 1 B3.06       1 SFTP50

- 5 TPGX 090202L DC100
- 1 TPGX 110302L DC100
- 2 WCGT 020102L DC 10

REF.	CODE	kg
KIT K01 TRM50/80	655005010802	6.2
KIT K01 TRM80/80	655008010802	6.6

### KIT K01 TRM 50/63 - 63/63

### Campo di Lavoro

Ø 6-30

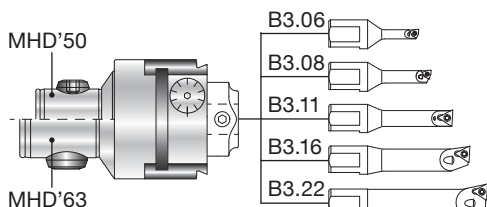

Ø 30-77

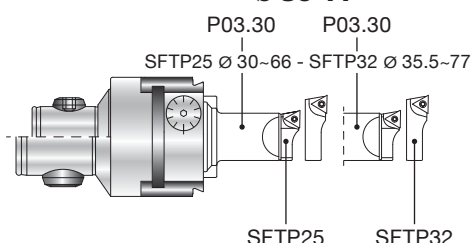

Ø 77-125

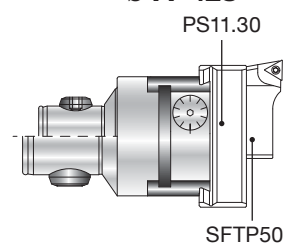

### KIT K01 TRM 50/80 - 80/80

### Campo di Lavoro

Ø 6-30

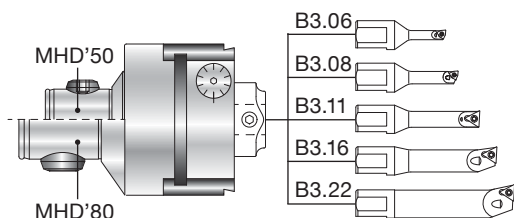

Ø 30-95

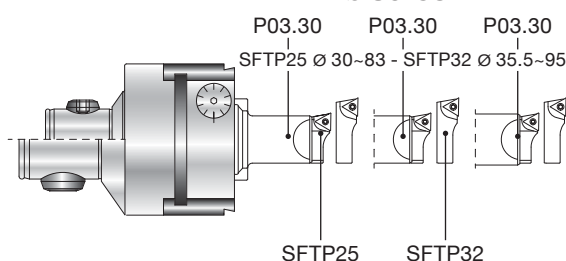

Ø 95-220

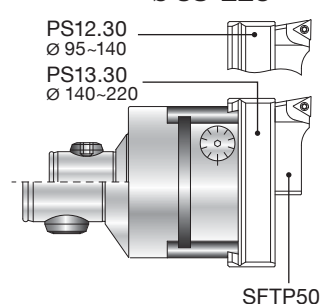

REF.	CODE	TORX T	kg
B1.02	572010502001		0.02
B1.04	572010504001		0.02
B3.06	572010506001 WCGT0201..	TS 21 06	0.035
B3.08	572010508001 WCGT0201..	TS 211 06	0.4
B3.10	572010510001 TPGX0902..	CS 250 T 08	0.05
B3.11	572010511001 TPGX0902..	CS 250 T 08	0.055
B3.12	572010512001 TPGX0902..	CS 250 T 08	0.06
B3.14	572010514001 TPGX0902..	CS 250 T 08	0.07
B3.16	572010516001 TPGX0902..	CS 250 T 08	0.07
B3.18	572010518001 TPGX0902..	CS 250 T 08	0.1
B3.22	572010522001 TPGX0902..	CS 250 T 08	0.1

REF.	CODE	TORX T	kg
SFTP25	470500525001 TPGX0902..	CS 250T 08	0.01
SFTP32	470500532001 TPGX0902..	CS 250T 08	0.02
SFTP50	470500550001 TPGX1103..	CS300890T 08	0.08
SFTP51	470500550003 TCMT16T3..	TS 4 15	0.09

REF.	CODE	TORX T	kg
B5.06	572010506105 WCGT0201..	TS 21 06	0.075
B5.08	572010508105 WCGT0201..	TS 211 06	0.09
B5.10	572010510105 TPGX0902..	CS 250 T 08	0.1
B5.12	572010512105 TPGX0902..	CS 250 T 08	0.1
B5.14	572010514105 TPGX0902..	CS 250 T 08	0.2
B5.16	572010516105 TPGX0902..	CS 250 T 08	0.3
B8.06	572010506108 WCGT0201..	TS 21 06	0.065
B8.08	572010508108 WCGT0201..	TS 211 06	0.08
B8.10	572010510108 TPGX0902..	CS 250 T 08	0.1
B8.12	572010512108 TPGX0902..	CS 250 T 08	0.2
B8.14	572010514108 TPGX0902..	CS 250 T 08	0.2
B8.16	572010516108 TPGX0902..	CS 250 T 08	0.3

REF.	CODE	TORX T	kg
SFCC25	470500525002 CCGT0602..	TS 25 08	0.01
SFCC32	470500532002 CCGT0602..	TS 25 08	0.02
SFCC50	470500550002 CCGT09T3..	TS 4 15	0.08
SFCC51	470500550004 CCMT1204..	TS 5 25	0.09

• Per lavorazioni SOTTOSQUADRA vedere p.26



## TRM 80/125 $\varnothing 36 \sim 500$

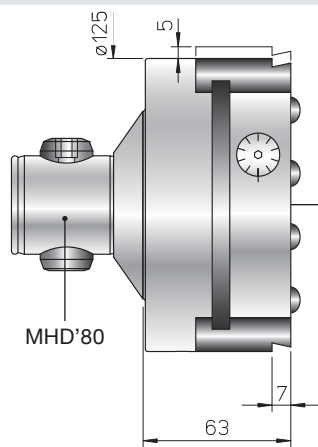

TRM 80/125

$\varnothing 36-500$

$\varnothing 36-125$

$\varnothing 50-138$

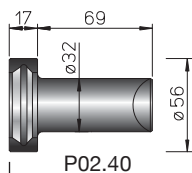

P02.40

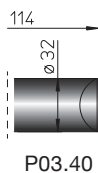

P03.40

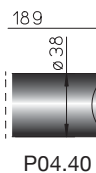

P04.40



SFTP32

SFCC32

SFTP40

SFCC40

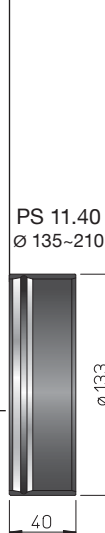

PS 11.40  
 $\varnothing 135-210$

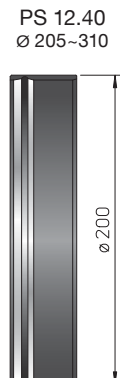

PS 12.40  
 $\varnothing 205-310$

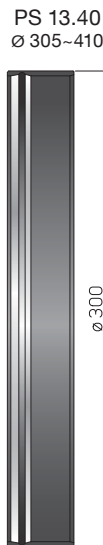

PS 13.40  
 $\varnothing 305-410$

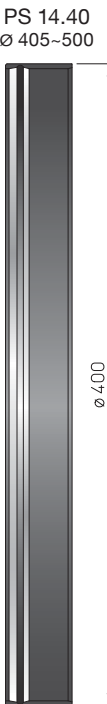

PS 14.40  
 $\varnothing 405-500$



SFTP50

SFCC50

SFTP51

SFCC51

$\varnothing 135-500$

**2  $\mu$ m**

REF.	CODE	kg
TRM 80/125	455008001251	5.5
P02.40	431040320700	0.7
P03.40	431040321150	1
P04.40	431040321900	2

REF.	CODE	kg
PS 11.40	433040351500	1.5
PS 12.40	433040352300	2.4
PS 13.40	433040353300	3.5
PS 14.40	433040354000	4.6

## KIT K03 $\varnothing 36 \sim 410$

TRM 80/125 ESCULSA



- 1 PS11.40
- 1 PS12.40
- 1 PS13.40
- 1 PS13.40
- 1 P02.40
- 1 P03.40
- 1 P04.40
- 1 SFTP32
- 1 SFTP40
- 1 SFTP50

$\varnothing 36-138$

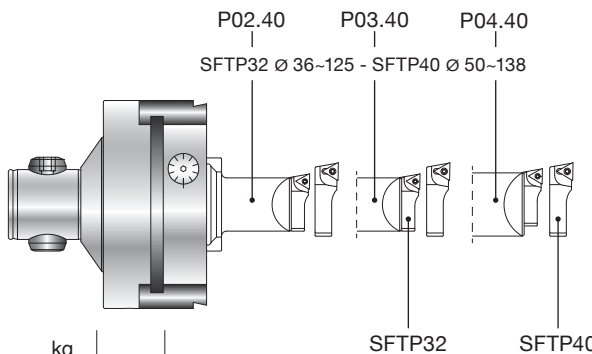

$\varnothing 135-410$

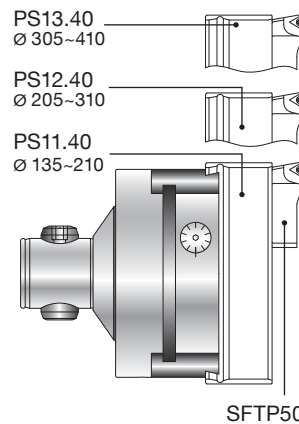

REF.	CODE	kg
KIT K03 TRM 80/125	655012500030	11.2

REF.	CODE	TRA	CS	TORX T	kg
SFTP32	470500532001	TPGX 0902..	CS 250T	08 0.02	
SFTP40	470500540001	TPGX 1103..	CS300890T	08 0.04	
SFTP50	470500550001	TPGX 1103..	CS300890T	08 0.08	
SFTP51	470500550003	TCMT 16T3..	TS 4	15 0.09	

REF.	CODE	CCGT	TS	TORX T	kg
SFCC32	470500532002	CCGT 0602..	TS 25	08 0.02	
SFCC40	470500540002	CCGT 09T3..	TS 4	15 0.04	
SFCC50	470500550002	CCGT 09T3..	TS 4	15 0.08	
SFCC51	470500550004	CCMT 1204..	TS 5	25 0.09	

## TRC 16 ~ 80 Ø 18 ~ 132



### TRC 16 Ø 18 ~ 24

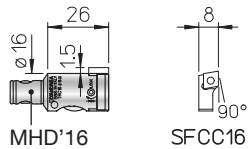

### TRC 40 Ø 48 ~ 66

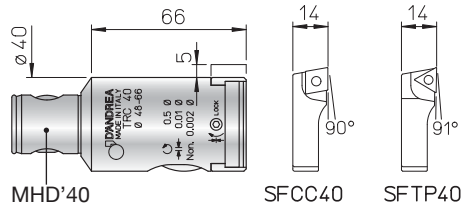

### TRC 20 Ø 22 ~ 30

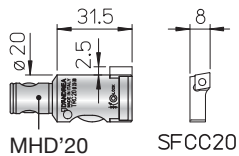

### TRC 50 Ø 54 ~ 86

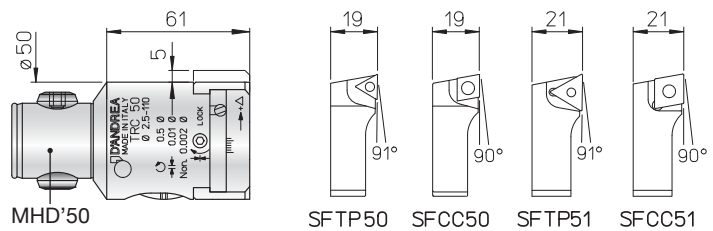

LA TRC 50 UTILIZZA TUTTI GLI UTENSILI A CORREDO DELLA TRM 50 (p.20-21)

### TRC 25 Ø 28 ~ 40

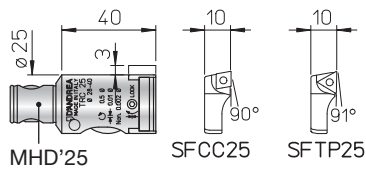

### TRC 63 Ø 72 ~ 110

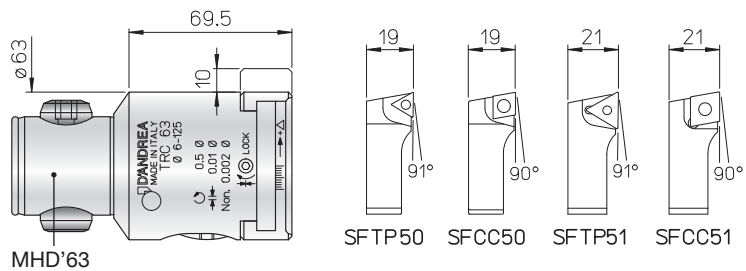

### TRC 32 Ø 35.5 ~ 53.5

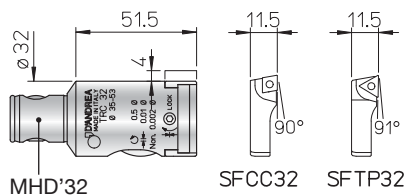

### TRC 80 Ø 88 ~ 132

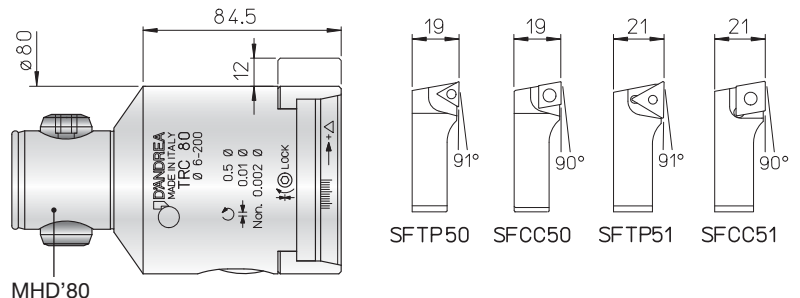

REF.	CODE	kg		
TRC 16	455011600341	0.05		
TRC 20	455012000401	0.1		
TRC 25	455012500501	0.2		
TRC 32	455013200631	0.35		
TRC 40	455014000801	0.7		
TRC 50	455015000801	1		
TRC 63	455016301001	2		
TRC 80	455018001201	3.8		

REF.	CODE		TORX T	kg		
SFCC16	470500516002	CCGT 0602..	TS 25	08	0.003	
SFCC20	470500520002	CCGT 0602..	TS 25	08	0.005	
SFCC25	470500525002	CCGT 0602..	TS 25	08	0.01	
SFCC32	470500532002	CCGT 0602..	TS 25	08	0.02	
SFCC40	470500540002	CCGT 09T3..	TS 4	15	0.04	
SFCC50	470500550002	CCGT 09T3..	TS 4	15	0.08	
SFCC51	470500550004	CCMT 1204..	TS 5	25	0.09	
SFTP25	470500525001	TPGX 0902..	CS 250T	08	0.01	
SFTP32	470500532001	TPGX 0902..	CS 250T	08	0.02	
SFTP40	470500540001	TPGX 1103..	CS300890T	08	0.04	
SFTP50	470500550001	TPGX 1103..	CS300890T	08	0.08	
SFTP51	470500550003	TCMT 16T3..	TS 4	15	0.09	

• Per lavorazioni SOTTOSQUADRA vedere p.26

## MHD' TS / PSC TS

**TS 16/16**  
20-24



**TS 20/20**  
23.5-30

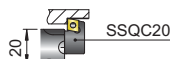

**TS 25/25**  
29.5-40

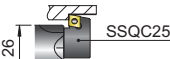

**TS 32/32**  
39-52

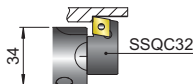

**TS 40/40**  
51-70

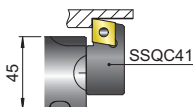

**TS 50/50**  
69-92

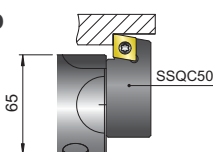

**TS 50/63**  
**TS 63/63**  
91-122

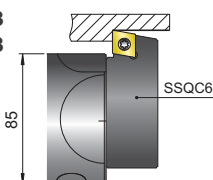

**TS 80/80**  
SSQC80  
121-162

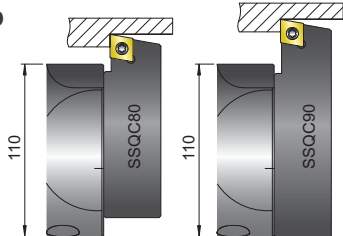

SSQC90  
161-202

**TS 80/160**  
SSQC90  
161-202

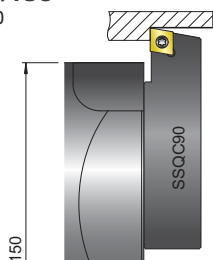

## TRM - TRC

**TRM 16** 20-25  
**TRC 16** 20-26



**TRM 20** 24.5-32  
**TRC 20** 24.5-33



**TRM 25** 31.5-40.5  
**TRC 25** 31.5-42.5



**TRM 32** 38.5-51.5  
**TRC 32** 38.5-53.5

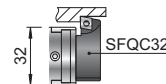

**TRM 40** 50.5-65  
**TRC 40** 50.5-67

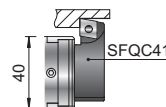

**TRM 50** 56-111  
**TRC 50** 56-113.5

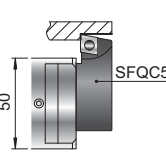

## CALCOLO MINIMO Ø INGRESSO

$$B \varnothing \text{ min} = (\varnothing C + \varnothing A + 1) : 2$$

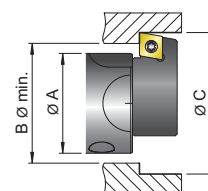

## QUOTE SEGGI

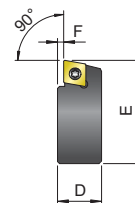

## TRM

**TRM 50/63**  
**TRM 63/63**

PS 11.30  
82-102  
PS 12.30  
100-127

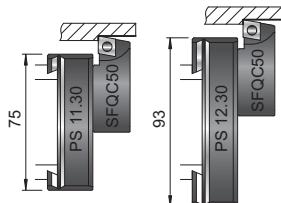

**TRM 50/80**  
**TRM 80/80**

PS 12.30  
100-142  
PS 13.30  
142-162

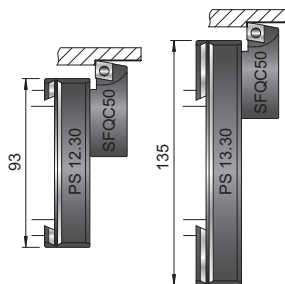

**TRM 80/125**

PS 11.40  
140-212  
PS 12.40  
210-312  
PS 13.40  
310-412  
PS 14.40  
410-502

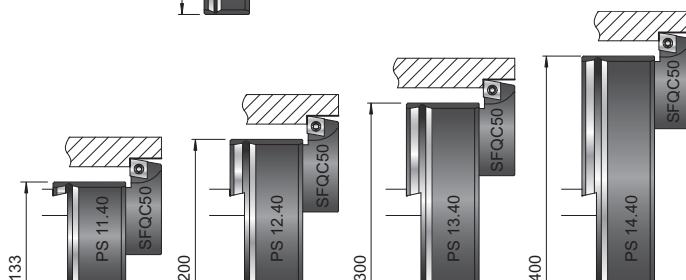

## TRC

**TRC 63**  
72.5-115

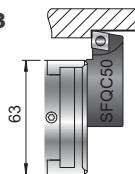

**TRC 80**  
88.5-135.5

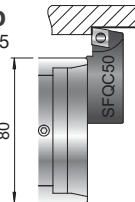

REF.	CODE	D	E	F	CCMT	TS	TORX	T
SSQC 16	470500516261	10	16	2	0602..	25	08	
SSQC 20	470500520261	11	19.5	1.5	0602..	25	08	
SSQC 25	470500525261	14.5	24	2.5	0602..	25	08	
SSQC 33	470500533261	17	32	3	09T3..	4	15	
SSQC 41	470500541261	21	42	3.5	1204..	5	25	
SSQC 50	470500550261	24.5	57	3.5	1204..	5	25	
SSQC 63	470500563261	28.5	76	3.5	1204..	5	25	
SSQC 80	470500580261	31.5	101	3.5	1204..	5	25	
SSQC 90	470500590261	31.5	122	3.5	1204..	5	25	

REF.	CODE	D	E	F	CCMT	TS	TORX	T
SFQC 16	470500516062	10	18	2	0602..	25	08	
SFQC 20	470500520062	10.5	22.5	2	0602..	25	08	
SFQC 25	470500525062	12	28.5	2.5	0602..	25	08	
SFQC 32	470500532062	13.5	35.5	2.5	0602..	25	08	
SFQC 40	470500540062	16.5	46	3	09T3..	4	15	
SFQC 50	470500550062	20.5	53	3	09T3..	4	15	

## PE ADATTATORI PER PINZE ELASTICHE

Pinze elastiche e chiavi di serraggio escluse

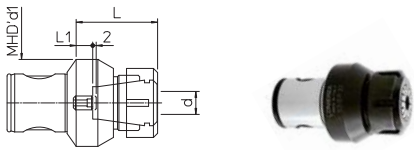

REF.	CODE	MHD' d1	d	L	L1	kg			N·m
PE 20 / ER16M	655702000160	20	0.5-10	32	1	0.06	ER-16M	E16M	40
PE 32 / ER25M	655703200250	32	1-16	42	1.5	0.25	ER-25M	E25M	160
PE 40 / ER25	655704000250	40	1-16	45	5	0.4	UM/ER25	E25	200
PE 50 / ER25	655705000250	50	1-16	48	7	0.7	UM/ER25	E25	200
PE 50 / ER32	655705000320	50	2-20	55	8	1	UM/ER32	E32	220
PE 63 / ER32	655706300320	63	2-20	59	12	1.3	UM/ER32	E32	220

## FORCE ADATTATORI A FORTE SERRAGGIO

**new**

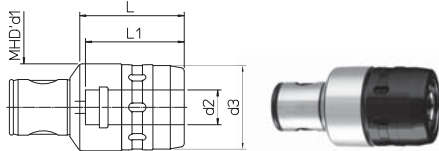

Pinze elastiche e chiavi di serraggio escluse

REF.	CODE	MHD' d1	d2	d3	L	L1	kg
FORCE 50/20	656305000200	50	20	48	60	60	1
FORCE 63/32	656306300320	63	32	66	80	80	2

## AW ADATTATORI WELDON WHISTLE NOTCH

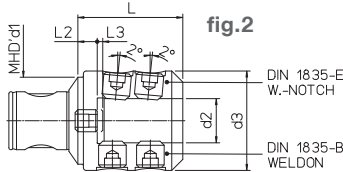
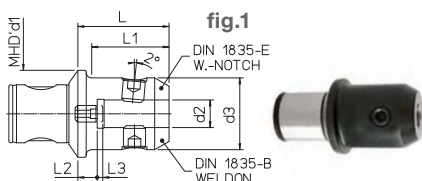

REF.	CODE	MHD' d1	d2 <sup>H5</sup>	d3	L	L1	L2	L3	kg	fig.
AW 50/6	655805000060	50	6	25	44	32.5	7	2	0.5	1
AW 50/8	655805000080	50	8	28	44	33	7	2	0.5	1
AW 50/10	655805000100	50	10	35	52	42	11	3	0.7	1
AW 50/12	655805000120	50	12	42	57	48	11	3	0.8	1
AW 50/14	655805000140	50	14	42	57	48	11	3	0.8	1
AW 50/16	655805000160	50	16	48	67	61	17	4	1.1	1
AW 50/20	655805000200	50	20	51	67		16	4	1.2	1
AW 50/25	655805000250	50	25	63	80		22	4	1.8	2
AW 63/16	655806300160	63	16	48	64	53	14	4	1.4	1
AW 63/20	655806300200	63	20	52	66	56	14	4	1.5	1
AW 63/25	655806300250	63	25	64	74		16	4	2.1	2
AW 63/32	655806300320	63	32	72	76		14	4	2.5	2
AW 80/40	655808000400	80	40	80	83		12	4	3.2	2

## PF ADATTATORI PER FRESE A DISCO E A SPIANARE

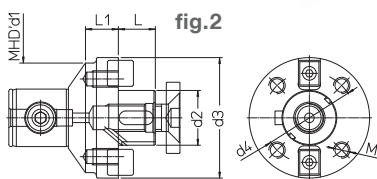
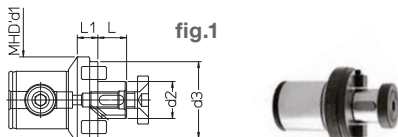

REF.	CODE	MHD' d1	d2	d3	d4	M	L	L1	kg	fig.
PF 40/16	655904020165	40	16	32			17	15	0.3	1
PF 40/22	655904020225	40	22	40			19	13	0.4	1
PF 50/16	655905000160	50	16	32			17	15	0.5	1
PF 50/22	655905000220	50	22	40			19	15	0.5	1
PF 50/27	655905000270	50	27	50			21	15	0.6	1
PF 50/32	655905000320	50	32	60			24	15	0.7	1
PF 63/22	655906300220	63	22	60			19	15	0.9	1
PF 63/27	655906300270	63	27	60			21	15	1.1	1
PF 63/32	655906300320	63	32	63			24	15	1.2	1
PF 80/32	655908000320	80	32	80			24	24	1.7	1
PF 80/40	655908000400	80	40	84	66.7	M12	27	24	1.9	2
PF 80/50	655908000500	80	50	90			30	24	2.0	2
PF 80/60	655908000600	80	60	128.5	101.6	M16	40	31.5	3.5	2

## MHD' 80 - HT 8 ADATTATORE MHD' 80 - HT 8

**new**

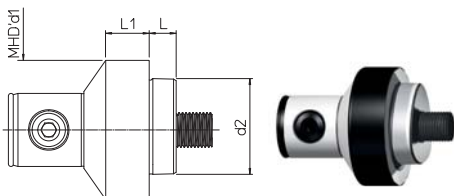

REF.	CODE	MHD' d1	d2	L	L1	kg
MHD'80-HT8	655108000080	80	HT8	15.5	25	2

## NS ADATTATORI SEMILAVORATI

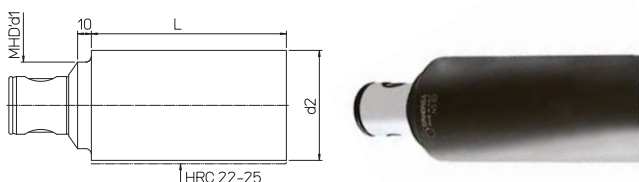

SPECIALI A RICHIESTA

REF.	CODE	MHD' d1	d2	L	kg
NS 50	657205001600	50	63	160	4.2
NS 63	657206302000	63	80	200	8.7
NS 80	657208002500	80	100	250	16

Linea di portautensili modulari di alta precisione che consente di eseguire differenti operazioni di asportazione di truciolo sulle più moderne macchine utensili.

Il punto di forza del sistema **PSC** è l'attacco poligonale-conico ISO 26623 che garantisce estrema rigidità anche nelle operazioni più gravose.

Il sistema permette l'impiego di tutta la linea **MHD'**.

## Attacco PSC ISO 26623-1/2

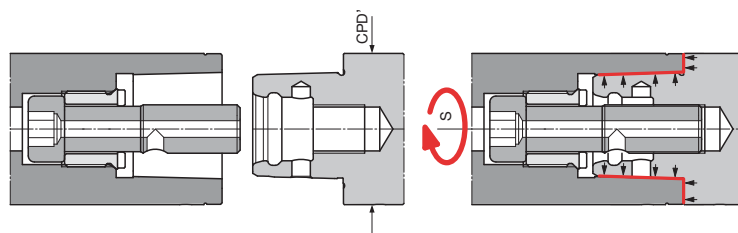

L'**attacco PSC** è conforme alla normativa ISO 26623 è disponibile in tre grandezze.

Il sistema è completo di attacchi base, prolunghe, riduzioni, adattatori, testine di sgrossatura e di finitura.

La gamma, prevede anche portapinze ER e mandrini a forte serraggio MONOFORCE.

PSC	S	⬡ N·m
40	8	55
50	10	95
63	14	170



**PSC - TS** linea completa di utensili bitaglienti per la sgrossatura da  $\varnothing$  68 mm. a  $\varnothing$  200 mm.



**PSC - TRM** linea completa di utensili micrometrici per la finitura da  $\varnothing$  2,5 mm. a  $\varnothing$  220 mm.

**ATTACCHI BASE** realizzati in 3 differenti grandezze C4, C5 e C6, sono prodotti in acciaio cementato, temprato e successivamente rettificato.



**MONOforce** Linea di portautensili a forte serraggio ideale per lavorazioni ove sussistano esigenze di precisione e necessità di serraggio utensili sollecitati ad elevati carichi torsionali.



**PSC - PE** Portapinze ER realizzati per l'impiego di pinze standard ER nelle operazioni di foratura.



**PSC - PR e RD** per ogni grandezza di PSC sono disponibili prolunghe e riduzioni in differenti lunghezze che consentono di raggiungere le profondità di lavoro richieste.

**PSC - MHD'** adattatori per integrare al programma PSC tutta la linea di alesatura del sistema MHD'.



**PF** adattatori per frese a disco e a spianare. Impiegato anche nelle lavorazioni di grandi diametri nella linea BHT.



# PSC Linea

## PSC

**PSC - TS**  
Teste  
Sgrossatura

**PSC - TRM 2µm**  
Testarossa

**PSC - PR**  
Prolunghe

**ADATTATORI**

**ALTRI  
ATTACCHI**

PSC50 - TS50  
Ø 68 - 90



**PSC 50**

PSC50 - TRM50  
Ø 2.5 - 108



PSC50 - PR50



PSC50 - RD50



PSC - PE  
Portapinzze elastiche



DIN - PSC



PSC - MF  
Forte serraggio



MAS BT - PSC



PSC - PF  
Portafrese



HSK - PSC



PSC - NS  
Neutri



CAT - PSC



PSC63 - TS50  
Ø 68 - 90



**PSC 63**

PSC63 - TS63  
Ø 90 - 120



PSC80 - TS80  
Ø 120 - 200



PSC63 - TRM50  
Ø 2.5 - 108



PSC63 - TRM63  
Ø 2.5 - 125



PSC63 - TRM80  
Ø 2.5 - 220



PSC63 - PR63



PSC63 - RD63



PSC80 - PR80



## MHD' Linea

**PR**  
Prolunghe

**RD**  
Riduzioni

**RAV**  
Riduzioni  
Antivibranti

**TS**  
Teste  
Sgrossatura **new**

**TRM 2µm**  
Testarossa

**TRC 10µm**  
Testarossa

**ADAT.**

**16**

PR 16



RD 32/16



RD 40/16



RD 50/16



RAV 50/16



TS 16/16  
Ø 18 - 22



TRM 16  
Ø 18 - 23



TRC 16  
Ø 18 - 24



PE Portapinzze elastiche



**20**

PR 20



RD 32/20



RD 40/20



RD 50/20



RAV 50/20



TS 20/20  
Ø 22 - 28



TRM 20  
Ø 22 - 29



TRC 20  
Ø 22 - 30



FORCE Forte serraggio



**25**

PR 25



RD 32/25



RD 40/25



RD 50/25



RAV 50/25



TS 25/25  
Ø 22 - 28



TRM 25  
Ø 22 - 29



TRC 25  
Ø 22 - 30



AW Weldon Whistle Notch

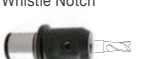

**32**

PR 32



RD 40/32



RD 50/32



RAV 50/32



TS 32/32  
Ø 35.5 - 50



TRM 32  
Ø 35.5 - 50



TRC 32  
Ø 35 - 53



PF Portafrese

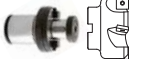

**40**

PR 40



RD 50/40



RAV 50/40



TS 40/40  
Ø 50 - 90



TRM 40  
Ø 48 - 63



TRC 40  
Ø 48 - 66



ATTACCHI  
PSC A MHD'

**PSC50 - MHD'**



**50**

PR 50



RD 63/50



RD 80/50



RAV 63/50



TS 50/50 - 50/63  
Ø 68 - 90



TRE 50 Ø 2.5 - 110



TRC 50  
Ø 6 - 110



TRM 50 Ø 2.5 - 108



**PSC63 - MHD'**



**63**

PR 63



RD 80/63



RAV 80/63



TS 63/63  
Ø 90 - 120



TRM 50/63 - 50/80  
Ø 2.5 - 220



TRC 63  
Ø 6 - 125



TRM 63/63 - 80/80  
Ø 2.5 - 220



**PSC80 - MHD'**



**80**

PR 80



RD 80/80



RAV 80/80



TS 80/80  
Ø 120 - 200



TRM 80/125  
Ø 2.5 - 500



TRC 80  
Ø 6 - 200



TS 80/90  
Ø 160 - 250



**new**

### DIN-AD - PSC DIN 69871 / ISO 26623-2

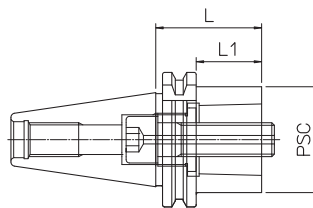

DIN	REF.	CODE	PSC	L	L1	kg
40	DIN69871-AD40 PSC 50.40	41PS05014028	50	40	21	0.9
50	DIN69871-AD50 PSC 50.30	41PS05015020	50	30	11	2.7
50	DIN69871-AD50 PSC 63.30	41PS06315028	63	30	11	2.8
50	DIN69871-AD50 PSC 80.70	41PS08015020	80	70	51	3.7

### MAS BT-AD - PSC MAS 403 BT / ISO 26623-2

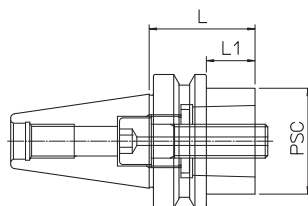

BT	REF.	CODE	PSC	L	L1	kg
40	MAS403 BT40-AD PSC 50.50	41PS05014032	50	50	23	1.2
50	MAS403 BT50-AD PSC 50.40	41PS05015030	50	40	2	3.4
50	MAS403 BT50-AD PSC 63.50	41PS06315032	63	50	12	3.5
50	MAS403 BT50-AD PSC 80.70	41PS08015030	80	70	32	4

### HSK-T - PSC DIN 69893 / ISO 26623-2

new

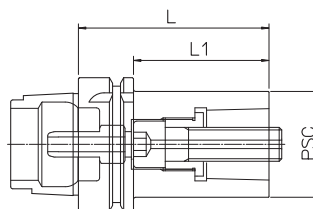

Completo di raccordo per il refrigerante

HSK-A	REF.	CODE	PSC	L	L1	kg
63	HSK-T63 PSC 40.80	41PS0405632T	40	80	54	1.1
63	HSK-T63 PSC 50.90	41PS0505632T	50	90	64	1.5
100	HSK-T100 PSC 50.100	41PS0505992T	50	100	71	3
100	HSK-T100 PSC 63.110	41PS0635992T	63	110	81	3.6
100	HSK-T100 PSC 80.120	41PS0805992T	80	120	91	4.7

### CAT-AD - PSC ANSI B5.50 / ISO 26623-2

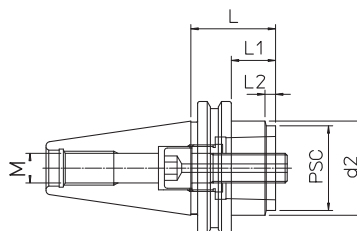

CAT	REF.	CODE	PSC	d2	L	L1	L2	M	kg
40	CAT40 AD PSC 50.50	41PS05014045	50	50	31			UNC 5/8-11	1
50	CAT50 AD PSC 50.40	41PS05015045	50	69.9	40	21	5	UNC 1/8	2.5
50	CAT50 AD PSC 63.50	41PS06315045	63	70	50	31	12.5	UNC 1/8	3
50	CAT50 AD PSC 80.100	41PS08015045	80	100	81			UNC 1/8	4.6

## PSC - PR ISO 26623-1 / 2

PROLUNGHE

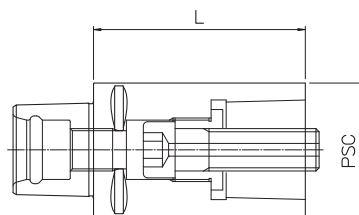

PSC	REF.	CODE	L	kg		
40	PR PSC 40.60	656PS04006000	60	0.55		
50	PR PSC 50.80	656PS05008000	80	1.1		
63	PR PSC 63.100	656PS06310000	100	2.2		
80	PR PSC 80.100	656PS08010000	100	3.6		

## PSC - RD ISO 26623-1 / 2

RIDUZIONI

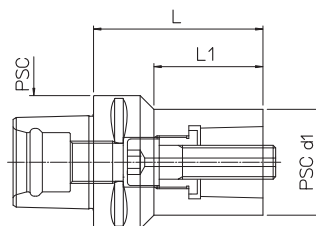

PSC	REF.	CODE	PSCd1	L	L1	kg		
50	RD PSC 50/40.65	657PS05004000	40	65	45	0.7		
63	RD PSC 63/40.80	657PS06304000	40	80	51.4	1.3		
63	RD PSC 63/50.80	657PS06305000	50	80	51.5	1.5		
80	RD PSC 80/50.80	657PS08005000	50	80	49.3	2.2		
80	RD PSC 80/63.80	657PS08006300	63	80	53.1	2.5		

## PSC - MHD' ISO 26623-1

RIDUZIONI A MODULARE

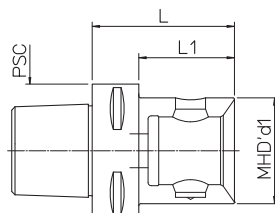

PSC	REF.	CODE	MHD' d1	L	L1	kg		
50	PSC 50 - MHD' 50.55	416502605005	50	55		0.8		
63	PSC 63 - MHD' 40.50	416402606305	40	50	28	0.9		
63	PSC 63 - MHD' 50.55	416502606305	50	55	33	0.8		
63	PSC 63 - MHD' 63.77	416632606307	63	77		1.8		
80	PSC 80 - MHD' 50.60	416502608006	50	60	30	2		
80	PSC 80 - MHD' 63.70	416632608007	63	70	40	2.3		
80	PSC 80 - MHD' 80.75	416802608007	80	75		2.6		

A richiesta Raccordo Refrigerante **PSC** vedere pag. 51





## PSC - TS Ø 68 ~ 200

Teste di sgrossatura semplici ed estremamente rigide grazie alle superfici di contatto dentellate tra il corpo testa e i seggi portainsero. La distanza costante tra la vite di serraggio del seggio ed il tagliente garantisce la stabilità del sistema.

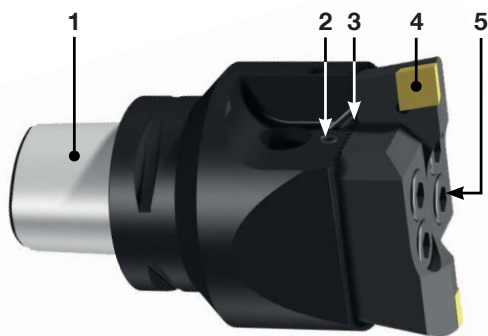

1. PSC 50 - 63 - 80
2. Vite di regolazione
3. Fori uscita refrigerante Max BAR 40
4. Seggio portainseri
5. Viti bloccaggio utensile

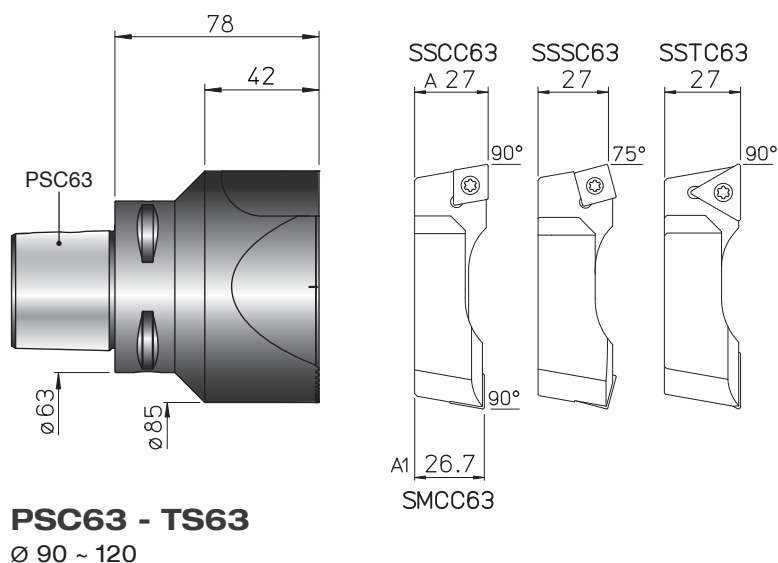
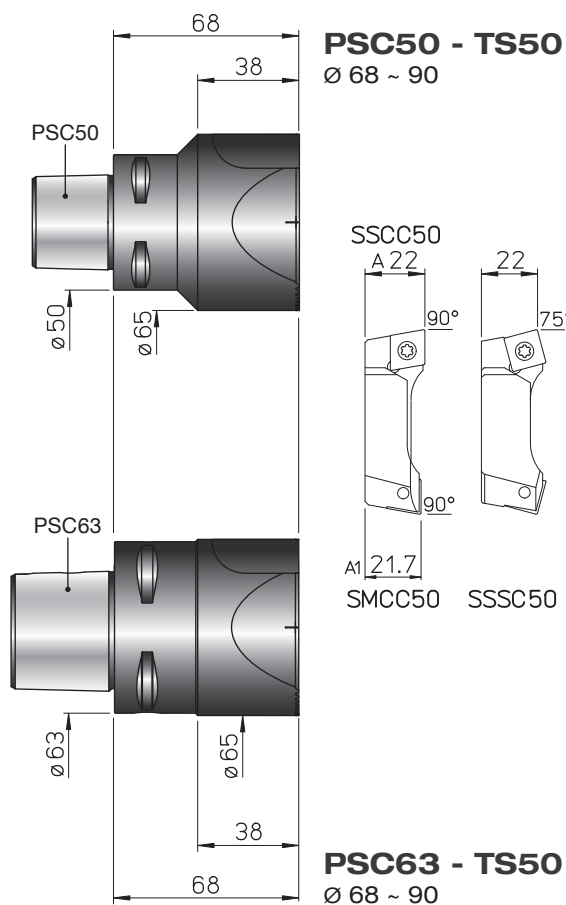

REF.	CODE	kg		
<b>PSC50 - TS50</b>	71PSC050TS50090	1.4		
<b>PSC63 - TS50</b>	71PSC063TS50090	1.8		
<b>PSC63 - TS63</b>	71PSC063TS63105	2.7		
<b>PSC63 - TS80</b>	71PSC063TS80115	3.8		

A richiesta Raccordo Refrigerante **PSC** vedere pag. 51



# PSC - TS TESTE SGROSSATURA

## IMPIEGO PSC - TS per operazioni di SGROSSATURA e SEMI-FINITURA

La regolazione dei taglienti va eseguita su un banco di presetting e le testine **PSC-TS** possono essere utilizzate in tre diverse configurazioni. Per lavorare con un solo tagliente o con differenti diametri di taglio, dimezzare.

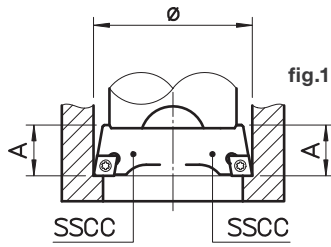

**fig.1** con due seggi SSCC allineati e sullo stesso diametro per operazioni di sgrossatura con forti avanzamenti.

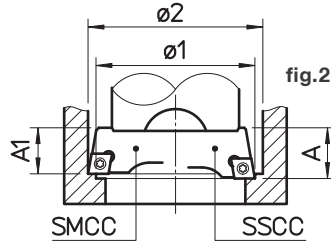

**fig. 2** con un seggio SSCC ed un seggio SMCC disallineato e su un diverso diametro per operazioni di sgrossatura con alte profondità di passata.

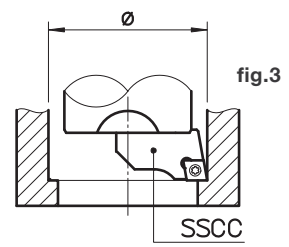

**fig.3** con un solo seggio per operazioni di sgrossatura leggera o semifinitura.

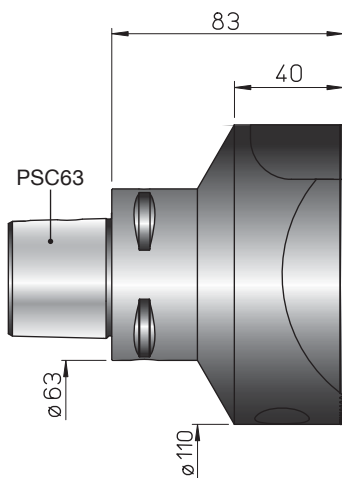

**PSC63 - TS80**  
Ø 120 ~ 200

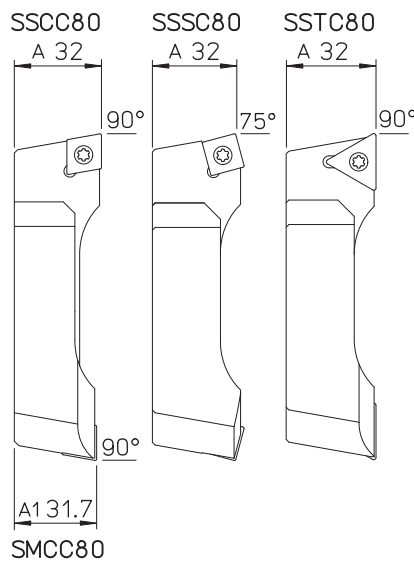

Ø 120-160

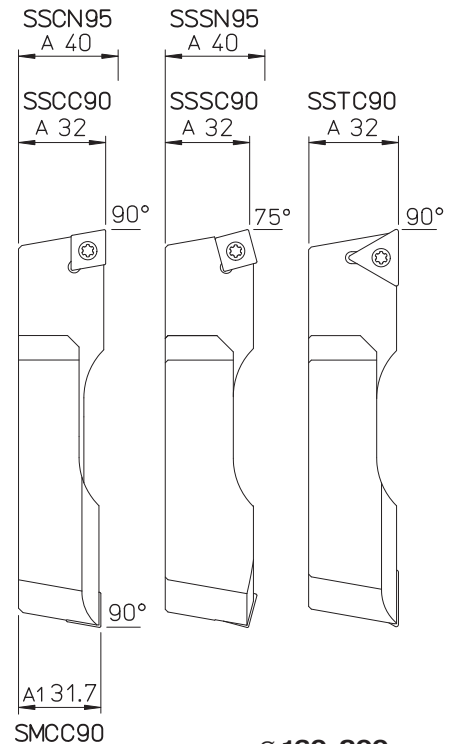

Ø 160-200

REF.	CODE	TS TORXT	kg
SSCC 50	470500550204	CCMT 1204..	5 25 0.1
SSCC 63	470500563201	CCMT 1204..	5 25 0.2
SSCC 80	470500580201	CCMT 1204..	5 25 0.5
SSCC 90	470500590201	CCMT 1204..	5 25 0.7
SSCN 95	470500595201	CNM. 1906..	0.9
SSTC 63	470500563206	TCMT 2204..	5 25 0.2
SSTC 80	470500580206	TCMT 2204..	5 25 0.5
SSTC 90	470500590206	TCMT 2204..	5 25 0.7

REF.	CODE	TS TORXT	kg
SMCC 50	470500550205	CCMT 1204..	5 25 0.1
SMCC 63	470500563203	CCMT 1204..	5 25 0.2
SMCC 80	470500580203	CCMT 1204..	5 25 0.5
SMCC 90	470500590203	CCMT 1204..	25 08 0.7
SSSC 50	470500550202	SCMT 1204..	5 25 0.1
SSSC 63	470500563202	SCMT 1204..	5 25 0.2
SSSC 80	470500580202	SCMT 1204..	5 25 0.5
SSSC 90	470500590202	SCMT 1204..	5 25 0.7
SSSN 95	470500595202	SNM. 1906..	0.9

• Per lavorazioni SOTTOSQUADRA vedere p.26

## PSC - PE



## PSC - FORCE



## PSC - PF



## PSC - NS



## PSC - PE

new

### ADATTATORI PER PINZE ELASTICHE

Pinze elastiche e chiavi di serraggio escluse -Predisposizione Chip

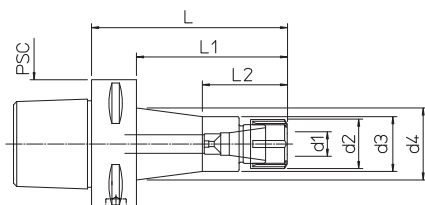

PSC	REF.	CODE	ER	d1	d2	d3	d4	L	L1	L2	kg
50	<b>PSC50 - ER16.55</b>	71PSC-050ER1605	16 <sub>M</sub>	0.5-10	22	24		55	35	26	0.5
50	<b>PSC50 - ER25.65</b>	71PSC-050ER2506	25	1-16	42			65	45		0.8
63	<b>PSC63 - ER16.60</b>	71PSC-063ER1606	16 <sub>M</sub>	0.5-10	22	24		60	38		0.85
63	<b>PSC63 - ER16.120</b>	71PSC-063ER1612	16 <sub>M</sub>	0.5-10	22	24	31	120	98	33	1.1
63	<b>PSC63 - ER25.65</b>	71PSC-063ER2506	25	1-16	42			65	43	37	1.1
63	<b>PSC63 - ER25.140</b>	71PSC-063ER2514	25	1-16	42		47.5	140	118	43.5	1.9
63	<b>PSC63 - ER32.75</b>	71PSC-063ER3207	32	2-20	50			75	53		1.5
63	<b>PSC63 - ER32.160</b>	71PSC-063ER3216	32	2-20	50			160	138		2.5
80	<b>PSC80 - ER25.70</b>	71PSC-080ER2507	25	1-16	42			70	40		2.1
80	<b>PSC80 - ER32.75</b>	71PSC-080ER3207	32	2-20	50			72	45		2.5

## PSC - FORCE

### FORTE SERRAGGIO

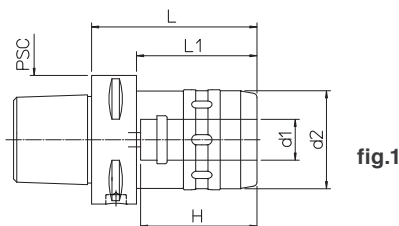

fig.1

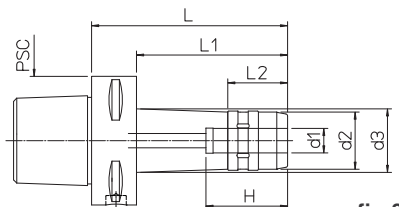

fig.2

Chiave di serraggio esclusa - Predisposizione Chip

PSC	REF.	CODE	d1	d2	d3	H	L	L1	L2	kg	fig.
63	<b>PSC 63 - MF 12.100</b>	71PSC-063MF1210	12	28	31.5	46	100	78	29.5	1.4	<b>2</b>
63	<b>PSC 63 - MF 20.80</b>	71PSC-063MF2008	20	48		60	80	58		1.3	<b>1</b>
63	<b>PSC 63 - MF 32.100</b>	71PSC-063MF3210	32	66		80	100			2.1	<b>1</b>
80	<b>PSC 80 - MF 20.80</b>	71PSC-080MF2008	20	48		60	80	50		3.7	<b>1</b>
80	<b>PSC 80 - MF 32.100</b>	71PSC-080MF3210	32	66		80	100	70		4.4	<b>1</b>

## PSC - PF

### PORTAFRESE

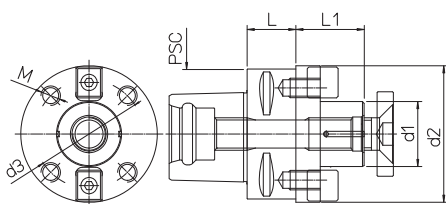

PSC	REF.	CODE	d1	d2	d3	M	L	L1	kg
50	<b>PSC 50 - PF22.25</b>	71PSC-050PF2202	22				25	19	0.5
50	<b>PSC 50 - PF27.25</b>	71PSC-050PF2702	27				25	21	0.6
63	<b>PSC 63 - PF27.25</b>	71PSC-063PF2702	27				25	21	0.8
63	<b>PSC 63 - PF32.25</b>	71PSC-063PF3202	32				25	24	0.9
80	<b>PSC 80 - PF32.30</b>	71PSC-080PF3203	32				30	24	1.8
80	<b>PSC 80 - PF40.45</b>	71PSC-080PF4004	40	84	66.7	M12	45	27	2.4

## PSC - NS

### ADATTATORI SEMILAVORATI

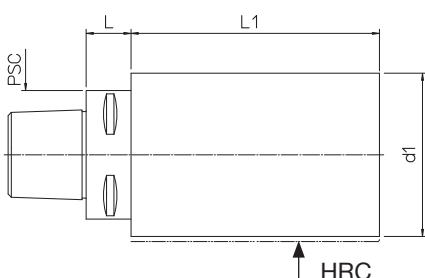

PSC	REF.	CODE	d1	L	L1	kg	HRC
50	<b>PSC 50 - NS 63.160/140 H.42</b>	71PSC050Z406314	63	20	140	3.8	<b>42</b>
50	<b>PSC 50 - NS 80.160/140 H.42</b>	71PSC050Z408014	80	20	140	10.2	<b>42</b>
50	<b>PSC 50 - NS 100.180/160 H.42</b>	71PSC050Z410016	100	22	160	5.9	<b>42</b>
63	<b>PSC 63 - NS 80.162/140 H.42</b>	71PSC063Z408014	80	22	140	6.2	<b>42</b>
63	<b>PSC 63 - NS 100.182/160 H.42</b>	71PSC063Z410016	100	22	160	10.4	<b>42</b>
63	<b>PSC 63 - NS 120.202/180 H.42</b>	71PSC063Z412018	120	22	180	17	<b>42</b>
80	<b>PSC 80 - NS 100.190/160 H.42</b>	71PSC080Z410016	100	30	160	11.5	<b>42</b>

A richiesta Raccordo Refrigerante **PSC** vedere pag. 51



PSC - TRM Ø 2.5 ~ 220

TESTE MICROMETRICHE  
2 µm

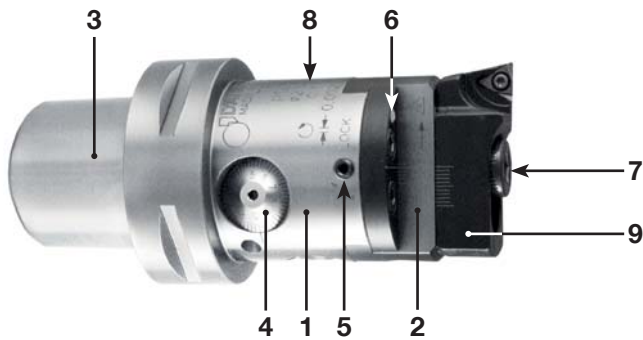

Le testine **PSC-TRM** consentono lavorazioni di alta precisione e ottima finitura superficiale in tolleranze di grado **IT6**. La sensibilità di regolazione di **1 micron** sul raggio è facilmente leggibile sul nonio ed eseguibile anche in macchina.

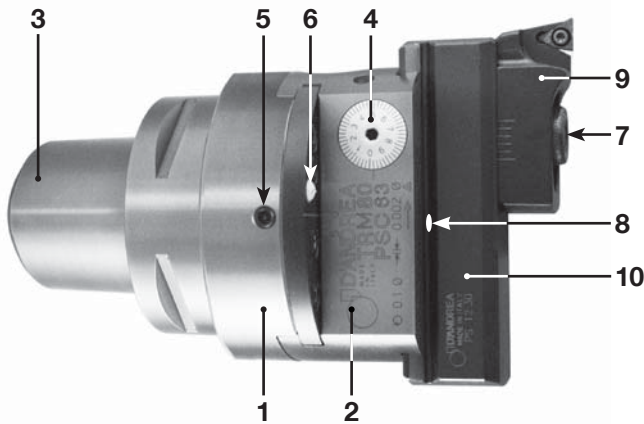

1. Corpo
2. Slitta portautensili
3. PSC 50-63-80
4. Nonio micrometrico
5. Vite bloccaggio slitta
6. Uscita refrigerante **Max BAR 40**
7. Viti bloccaggio utensili
8. Oliatore
9. Sedgio portainserti
10. Porta utensile



**PSC50 - TRM50**  
Ø 2.5 ~ 108



**PSC63 - TRM50**  
Ø 2.5 ~ 108

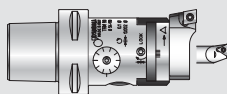

**PSC63 - TRM63**  
Ø 2.5 ~ 125



**PSC63 - TRM80**  
Ø 2.5 ~ 220



# PSC Linea

## PSC50 - TRM50

Ø 2.5 ~ 108



## PSC63 - TRM50

Ø 2.5 ~ 108



2 µm

**PSC50-TRM50**  
Ø 2.5-108

**PSC63-TRM50**  
Ø 2.5-108

Utensili RDC D08.16	Uten. antivibranti	Utensili metallo duro B1.02 Ø2,5-4 B1.04 Ø4-6

REF.	CODE	kg
PSC50-TRM50	71PSC050TR50080	0.9
PSC63-TRM50	71PSC063TR50080	1.1
D08.16	200560116082	0.02
P25.63	435116250631	0.5
P25.105	435116251051	0.8
PS 31.24	433024140751	0.19
CW 32	392011003201	0.07

A richiesta Raccordo Refrigerante **PSC** vedere pag. 51

# PSC - TRM MICROMETRICHE TESTAROSSA

## KIT K01 PSC50 - TRM50

Ø 6 ~ 108



- 1 PSC50-TRM50** 1 SFTP 25  
 1 B3.06 1 SFTP 32  
 1 B3.08 1 SFTP 50  
 1 B3.11 1 P 25.63  
 1 B3.16 1 PS 31.24  
 1 B3.22 1 CW 32
- 5 TPGX 090202L DC100  
 1 TPGX 110302L DC100  
 2 WCGT 020102L DC10

## KIT K01 PSC63 - TRM50

Ø 6 ~ 108



- 1 PSC63-TRM50** 1 SFTP 25  
 1 B3.06 1 SFTP 32  
 1 B3.08 1 SFTP 50  
 1 B3.11 1 P 25.63  
 1 B3.16 1 PS 31.24  
 1 B3.22 1 CW 32
- 5 TPGX 090202L DC100  
 1 TPGX 110302L DC100  
 2 WCGT 020102L DC10

REF.	CODE	kg
KIT K01 PSC50-TRM50	7KPSC050TR50080	3.5

REF.	CODE	kg
KIT K01 PSC63-TRM50	7KPSC063TR50080	4.2

### KIT K01 PSC50-TRM50 / PSC63-TRM50

### Campo di Lavoro

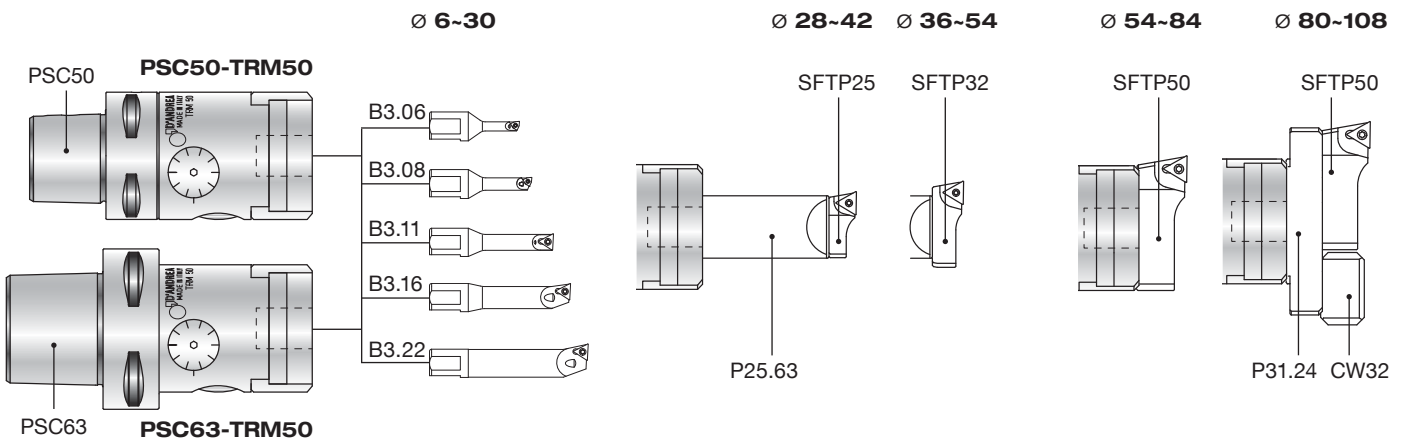

REF.	CODE	TORX T	kg
B1.02	572010502001		0.02
B1.04	572010504001		0.02
B3.06	572010506001	WCGT0201... TS 21 06	0.035
B3.08	572010508001	WCGT0201... TS 211 06	0.4
B3.10	572010510001	TPGX0902... CS 250 T 08	0.05
B3.11	572010511001	TPGX0902... CS 250 T 08	0.055
B3.12	572010512001	TPGX0902... CS 250 T 08	0.06
B3.14	572010514001	TPGX0902... CS 250 T 08	0.07
B3.16	572010516001	TPGX0902... CS 250 T 08	0.07
B3.18	572010518001	TPGX0902... CS 250 T 08	0.1
B3.22	572010522001	TPGX0902... CS 250 T 08	0.1

REF.	CODE	TORX T	kg
B5.06	572010506105	WCGT0201... TS 21 06	0.075
B5.08	572010508105	WCGT0201... TS 211 06	0.09
B5.10	572010510105	TPGX0902... CS 250 T 08	0.1
B5.12	572010512105	TPGX0902... CS 250 T 08	0.1
B5.14	572010514105	TPGX0902... CS 250 T 08	0.2
B5.16	572010516105	TPGX0902... CS 250 T 08	0.3
B8.06	572010506108	WCGT0201... TS 21 06	0.065
B8.08	572010508108	WCGT0201... TS 211 06	0.08
B8.10	572010510108	TPGX0902... CS 250 T 08	0.1
B8.12	572010512108	TPGX0902... CS 250 T 08	0.2
B8.14	572010514108	TPGX0902... CS 250 T 08	0.2
B8.16	572010516108	TPGX0902... CS 250 T 08	0.3

REF.	CODE	TORX T	kg
SFTP25	470500525001	TPGX0902... CS 250T 08	0.01
SFTP32	470500532001	TPGX0902... CS 250T 08	0.02
SFTP50	470500550001	TPGX1103... CS300890T 08	0.08
SFTP51	470500550003	TCMT16T3... TS 4 15	0.09

REF.	CODE	TORX T	kg
SFCC25	470500525002	CCGT0602... TS 25 08	0.01
SFCC32	470500532002	CCGT0602... TS 25 08	0.02
SFCC50	470500550002	CCGT09T3... TS 4 15	0.08
SFCC51	470500550004	CCMT1204... TS 5 25	0.09

• Per lavorazioni SOTTOSQUADRA vedere p.26

# PSC Linea

## PSC63 - TRM63

Ø 2.5 ~ 125



## PSC63 - TRM80

Ø 2.5 ~ 220



2 μm

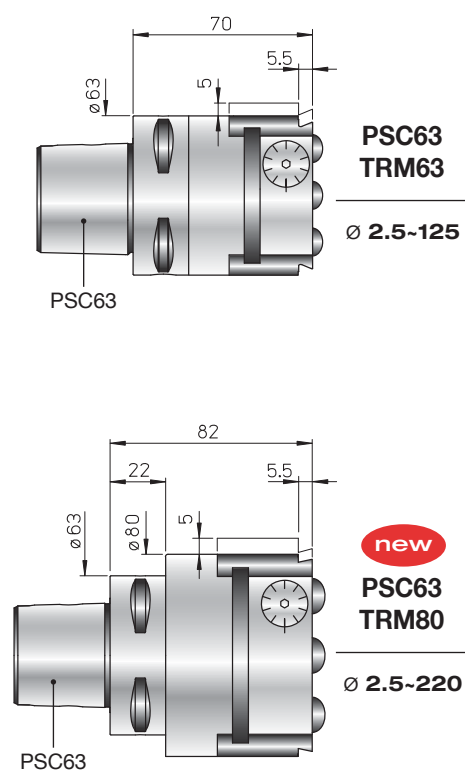

### Utensili

RDC D08.16

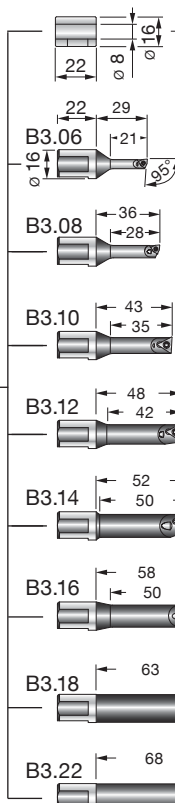

### Uten. antivibranti

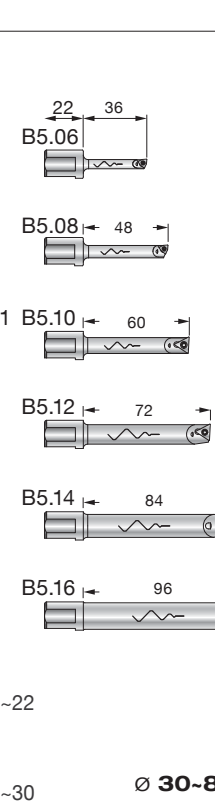

### Utensili metallo duro

B1.02 Ø2,5-4 B1.04 Ø4-6

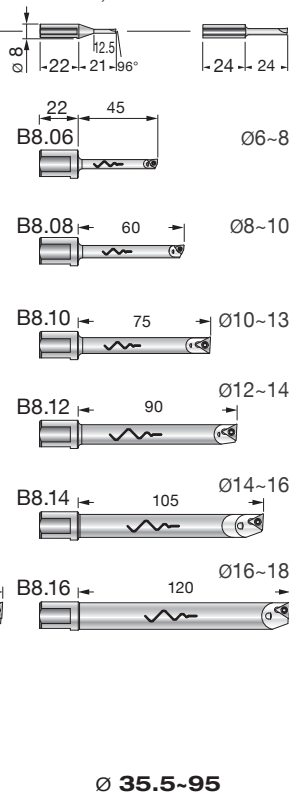

REF.	CODE	kg
PSC63-TRM63	71PSC063TR63080	1.5
PSC63-TRM80	71PSC063TR80080	2
D08.16	200560116082	0.02
P20.30	431030160300	0.2
P02.30	431030250400	0.3
P03.30	431030250700	0.4
P04.30	431030251150	0.7
PS 11.30	433030260750	0.4
PS 12.30	433030260950	0.5
PS 13.30	433030261400	0.7

A richiesta Raccordo Refrigerante **PSC** vedere pag. 51

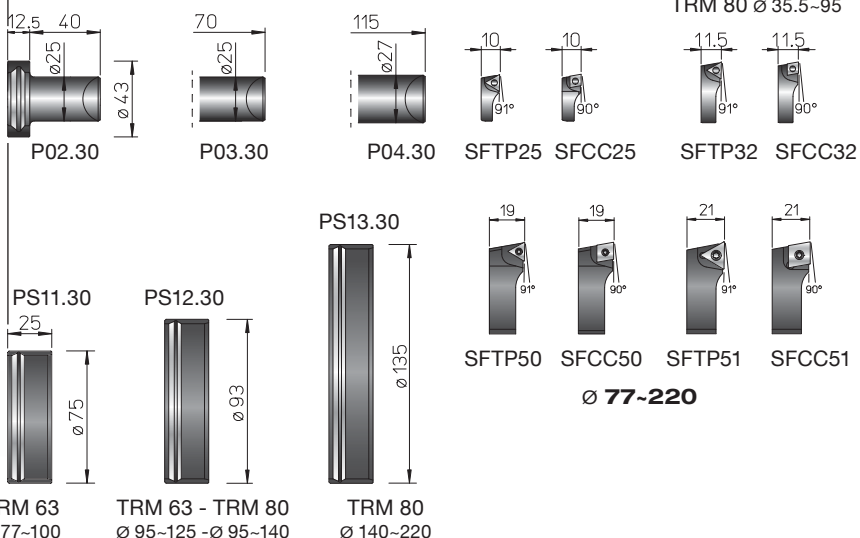

## KIT K01 PSC63 - TRM63

Ø 6 ~ 125



### 1 PSC63 - TRM63

- 1 P20.30      1 B3.11
- 1 PS11.30    1 B3.16
- 1 P02.30      1 B3.22
- 1 P03.30      1 SFTP25
- 1 B3.06       1 SFTP32
- 1 B3.08       1 SFTP50

- 5 TPGX 090202L DC100
- 1 TPGX 110302L DC100
- 2 WCGT 020102L DC 10

REF.	CODE	kg
KIT K01 PSC63-TRM63	7KPSC063TR63080	5.5

## KIT K01 PSC63 - TRM80

Ø 6 ~ 220



### 1 PSC63 - TRM80

- 1 P20.30      1 B3.08
- 1 PS12.30    1 B3.11
- 1 PS13.30    1 B3.16
- 1 P02.30      1 B3.22
- 1 P03.30      1 SFTP25
- 1 P04.30      1 SFTP32
- 1 B3.06       1 SFTP50

- 5 TPGX 090202L DC100
- 1 TPGX 110302L DC100
- 2 WCGT 020102L DC 10

REF.	CODE	kg
KIT K01 PSC63-TRM80	7KPSC063TR80080	6.5

### KIT K01 PSC63 - TRM63

### Campo di Lavoro

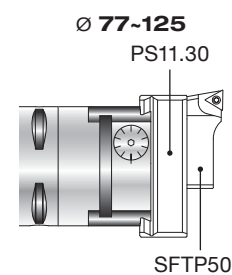
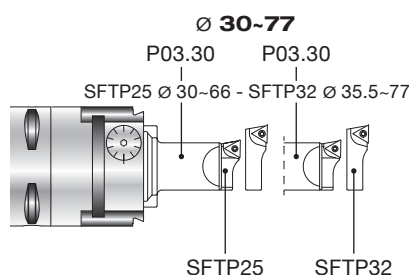
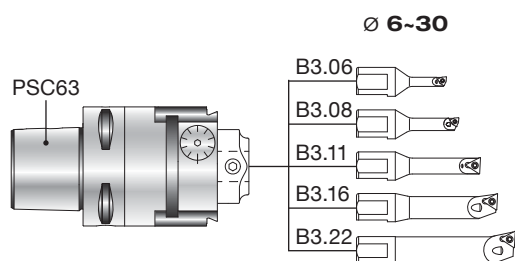

### KIT K01 PSC63 - TRM80

### Campo di Lavoro

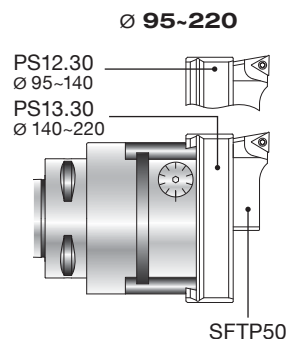
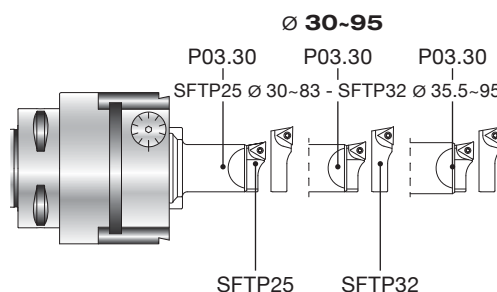
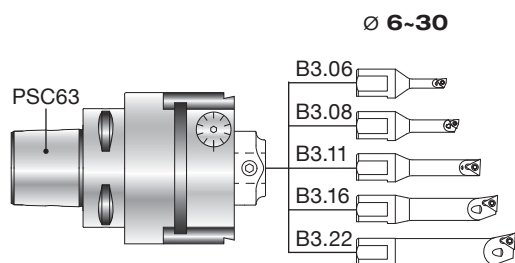

REF.	CODE	TORX T	kg
B1.02	572010502001		0.02
B1.04	572010504001		0.02
B3.06	572010506001	WCGT0201.. TS 21 06	0.035
B3.08	572010508001	WCGT0201.. TS 211 06	0.4
B3.10	572010510001	TPGX0902.. CS 250 T 08	0.05
B3.11	572010511001	TPGX0902.. CS 250 T 08	0.055
B3.12	572010512001	TPGX0902.. CS 250 T 08	0.06
B3.14	572010514001	TPGX0902.. CS 250 T 08	0.07
B3.16	572010516001	TPGX0902.. CS 250 T 08	0.07
B3.18	572010518001	TPGX0902.. CS 250 T 08	0.1
B3.22	572010522001	TPGX0902.. CS 250 T 08	0.1

REF.	CODE	TORX T	kg
SFTP25	470500525001	TPGX0902.. CS 250T 08	0.01
SFTP32	470500532001	TPGX0902.. CS 250T 08	0.02
SFTP50	470500550001	TPGX1103.. CS300890T 08	0.08
SFTP51	470500550003	TCMT16T3.. TS 4 15	0.09

REF.	CODE	TORX T	kg
B5.06	572010506105	WCGT0201.. TS 21 06	0.075
B5.08	572010508105	WCGT0201.. TS 211 06	0.09
B5.10	572010510105	TPGX0902.. CS 250 T 08	0.1
B5.12	572010512105	TPGX0902.. CS 250 T 08	0.1
B5.14	572010514105	TPGX0902.. CS 250 T 08	0.2
B5.16	572010516105	TPGX0902.. CS 250 T 08	0.3
B8.06	572010506108	WCGT0201.. TS 21 06	0.065
B8.08	572010508108	WCGT0201.. TS 211 06	0.08
B8.10	572010510108	TPGX0902.. CS 250 T 08	0.1
B8.12	572010512108	TPGX0902.. CS 250 T 08	0.2
B8.14	572010514108	TPGX0902.. CS 250 T 08	0.2
B8.16	572010516108	TPGX0902.. CS 250 T 08	0.3

REF.	CODE	TORX T	kg
SFCC25	470500525002	CCGT0602.. TS 25 08	0.01
SFCC32	470500532002	CCGT0602.. TS 25 08	0.02
SFCC50	470500550002	CCGT09T3.. TS 4 15	0.08
SFCC51	470500550004	CCMT1204.. TS 5 25	0.09

• Per lavorazioni SOTTOSQUADRA vedere p.26



**TCD'** è la linea di utensili e portautensili da tornio, realizzati seguendo le norme ISO 26623-1 PSC per l'applicazione sui mandrini di macchine MULTI-TASK.  
 Il programma **TCD'** è composto da adattatori portautensili di tornitura.  
 La linea **TCD'** è predisposta con il passaggio del liquido refrigerante.



## PSC - TU ISO 26623-1

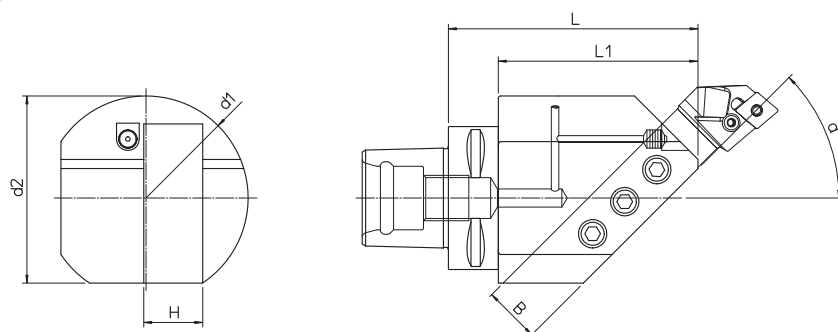

In figura portautensile destro. Seggi e chiavi di serraggio esclusi. L'utilizzo normale richiede un utensile sinistro in un adattatore destro.

PSC	REF.	CODE	L	L1	d1	d2	a°	BxH	kg		
50	TCD' PSC50 - TU20.45R	71PSC050T2045R1	90	70	72	65	45°	20x20	1.8		
50	TCD' PSC50 - TU20.45L	71PSC050T2045L1	90	70	72	65	45°	20x20	1.8		
63	TCD' PSC63 - TU25.45R	71PSC063T2545R1	110	88	90	82.5	45°	25x25	3.5		
63	TCD' PSC63 - TU25.45L	71PSC063T2545L1	110	88	90	82.5	45°	25x25	3.5		
80	TCD' PSC80 - TU32.45R	71PSC080T3245R1	135	105	115	98.5	45°	32x32	6.4		
80	TCD' PSC80 - TU32.45L	71PSC080T3245L1	135	105	115	98.5	45°	32x32	6.4		

A richiesta Raccordo Refrigerante **PSC** vedere pag. 51 

# ADATTATORI PORTAUTENSILI DI TORNITURA

## PSC - TU ISO 26623-1

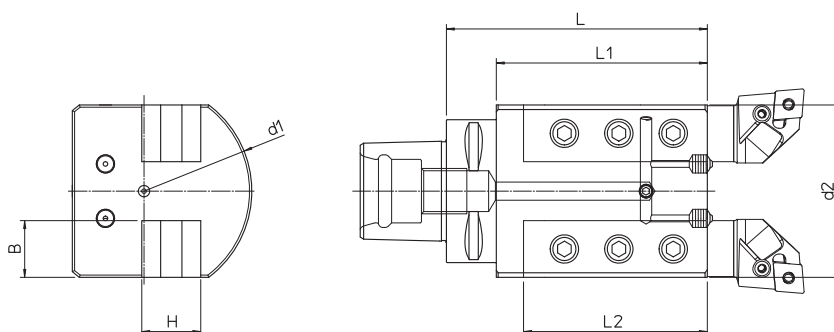

Seggi e chiavi di serraggio esclusi

PSC	REF.	CODE	L	L1	L2	d1	d2	BxH	kg		
50	TCD' PSC50 - TU20.02	71PSC050T200201	100	80	64	80	63	20x20	2.5		
63	TCD' PSC63 - TU25.02	71PSC063T250201	115	93	80	95	76	25x25	4		
80	TCD' PSC80 - TU32.02	71PSC080T320201	125	95	80	115	86	32x32	6.2		

## PSC - TU ISO 26623-1

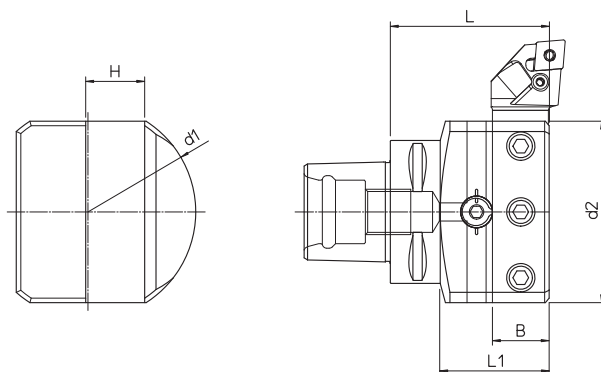

Seggi e chiavi di serraggio esclusi

PSC	REF.	CODE	L	L1	d1	d2	BxH	kg		
50	TCD' PSC50 - TU20.90	71PSC050T209001	60	40	80	64	20x20	1.4		
63	TCD' PSC63 - TU25.90	71PSC063T259001	70	48	95	80	25x25	2.6		
80	TCD' PSC80 - TU32.90	71PSC080T329001	85	55	133	105	32x32	5.2		

## PSC - D... ISO 26623-1

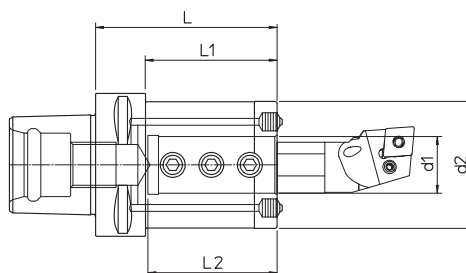

Seggi e chiavi di serraggio esclusi. **Bussole di riduzione a richiesta.**

PSC	REF.	CODE	d1H7	d2	L	L1	L2	kg		
50	TCD' PSC50 - D.25x80	71PSC050D250801	25	56	80	60	58	1.4		
63	TCD' PSC63 - D.25x80	71PSC063D250801	25	56	80	58	58	1.7		
63	TCD' PSC63 - D.40x125	71PSC063D401201	40	80	125	103	85	3.9		
80	TCD' PSC80 - D.25x85	71PSC080D250801	25	56	85	55	58	2.6		
63	TCD' PSC80 - D.40x125	71PSC080D401201	40	80	125	95	85	4.6		

A richiesta Raccordo Refrigerante **PSC** vedere pag. 51



Il nuovo sistema di barenatura **BHT**, è caratterizzato dal nuovo attacco base standard **HT** che assicura un perfetto accoppiamento ed una elevata resistenza alla torsione.

Le barre **BHT** coprono un campo di lavoro da Ø 250 a Ø 750 mm, sia in sgrossatura che in finitura.

L'ampia gamma di accessori comprende cartucce ISO-CA regolabili di sgrossatura ed una testina micrometrica di finitura TRM 63 STANDARD, in grado di eseguire operazioni di alesatura, smussi e lavorazioni in sottosquadra.

Il sistema in configurazione di FINITURA è bilanciabile mediante utilizzo di contrappesi.

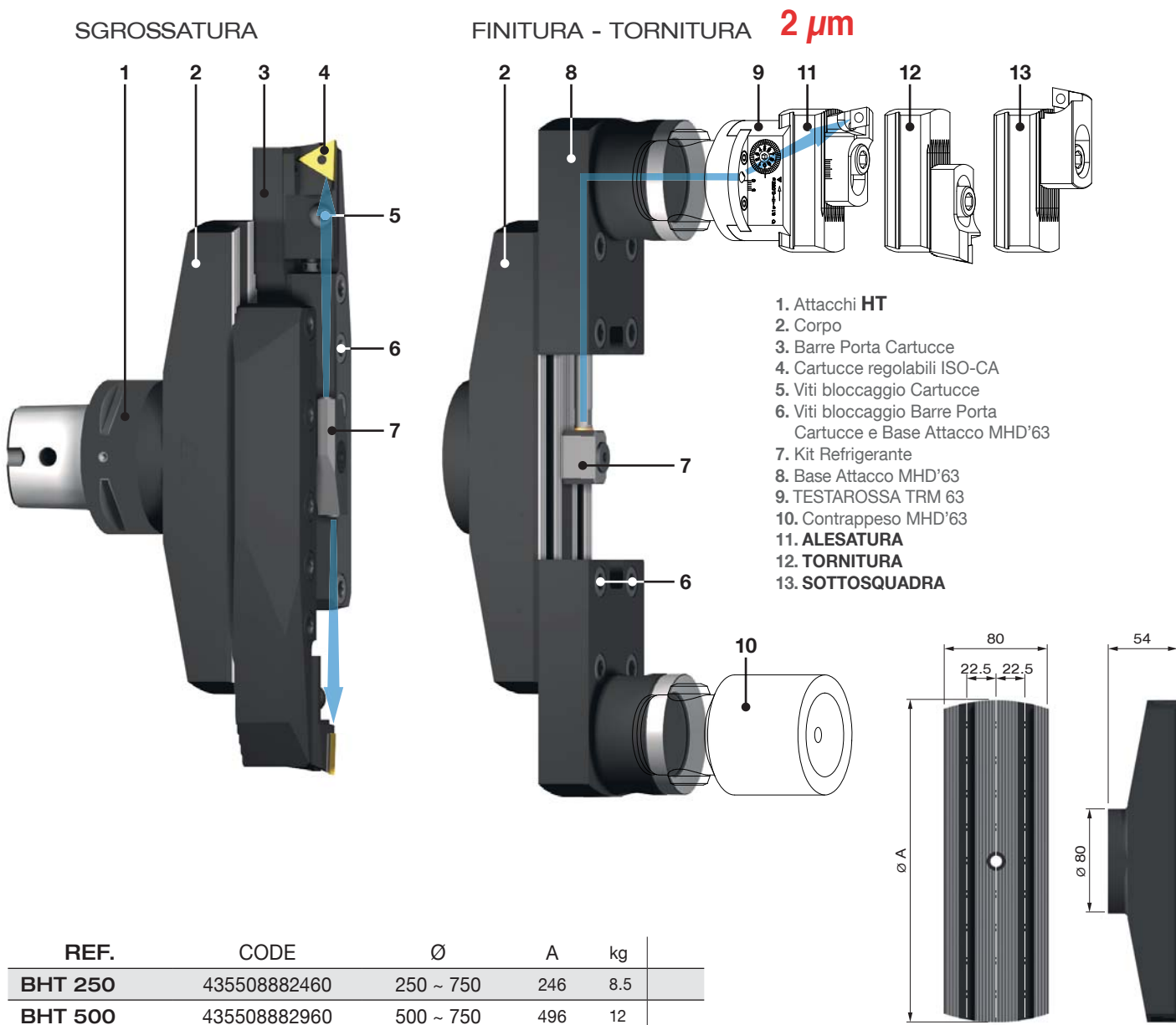

### ATTACCHI HT PATENTED

REF.	CODE
<b>DIN 69871-AD50 - HT8</b>	41HT08025000
<b>MAS403BT-AD50 - HT8</b>	41HT08035000
<b>PSC 80 - HT8</b>	41HT08018000
<b>HSK 100 - HT8</b>	41HT08041000
<b>MHD' 80 - HT8</b>	655108000080



**DIN 69871-AD50 - HT8**



**MAS403BT-AD50 - HT8**



**PSC-80 - HT8**



**HSK-100 - HT8**



**MHD'-80 - HT8**

# BHT BARRE MODULARI

## BHT Ø 250 ~ 750

### SGROSSATURA

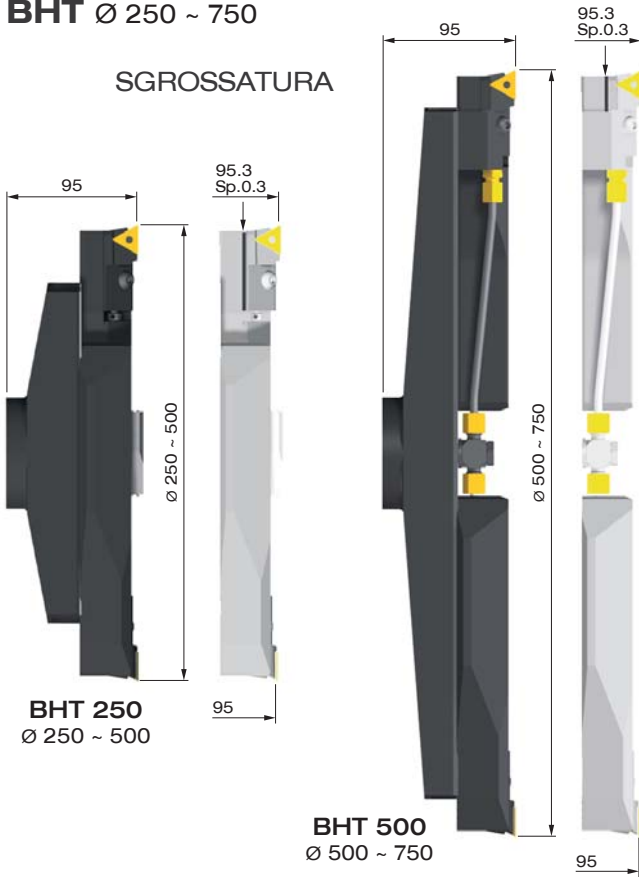

### FINITURA - TORNITURA 2 µm

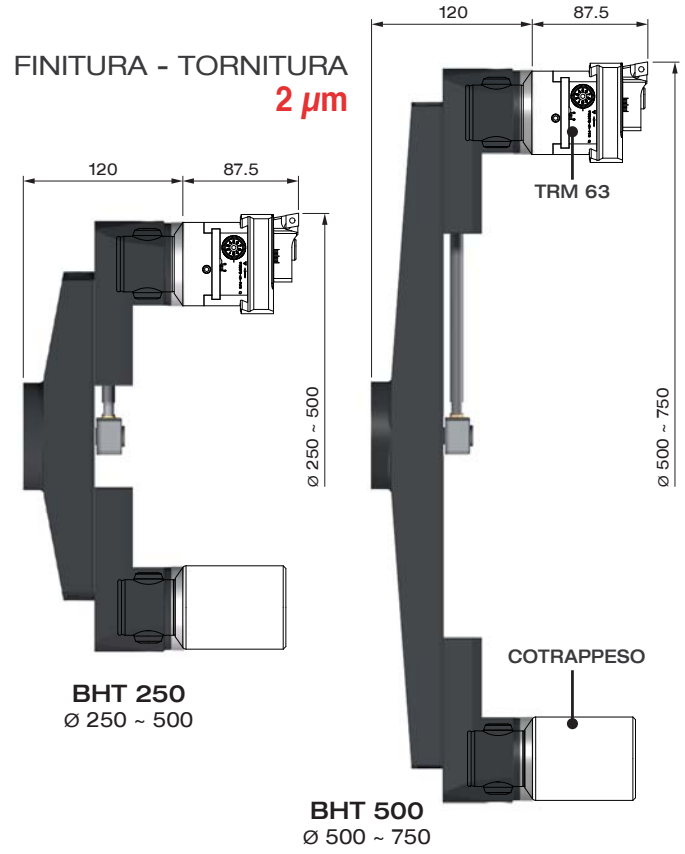

## BARRA PORTA CARTUCCE

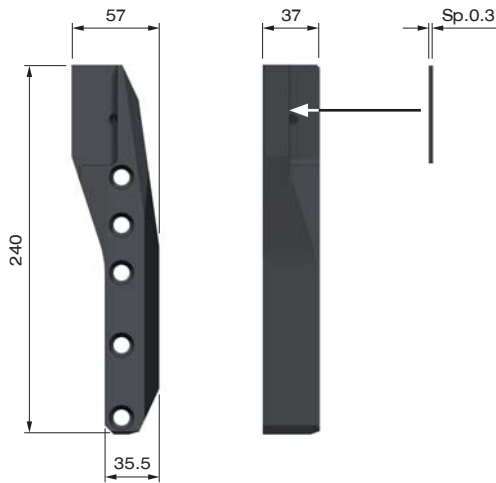



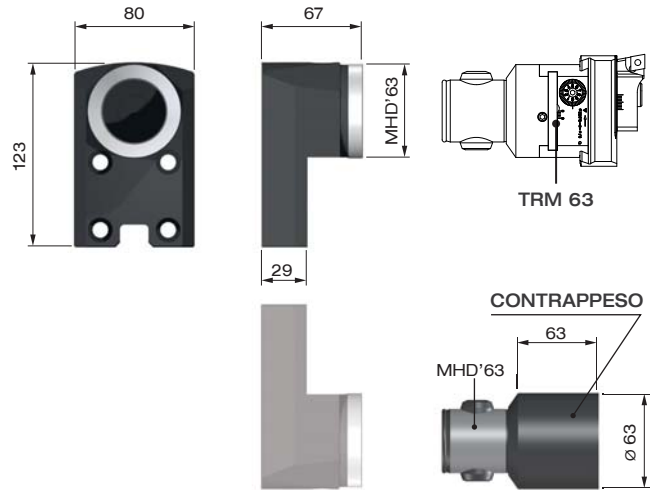

REF.	CODE
BARRA PORTA CARTUCCE BHT 250-500	382090024000

## BASE ATTACCO MHD'63



REF.	CODE
BASE ATTACCO MHD'63 BHT 250-500	382090006301
CONTRAPPESO MHD'63 BHT 250-500	392011006300

## KIT REFRIGERANTE

			
KIT RFG BHT 250 SG	KIT RFG BHT 500 SG	KIT RFG BHT 250 FN	KIT RFG BHT 500 FN
CODE 382090025000	CODE 382090050003	CODE 382090025001	CODE 382090050004

## CARTUCCE 20CA ISO 5611

			
PTGNL20CA-22	PCGNL20CA-16	SCGCL20CA-12	PSRNL20CA-15
CODE 483010201001	CODE 483010201002	CODE 483010201003	CODE 483010201004

# MONOforce

**MONOforce** portautensile a forte serraggio, adatto per lavorazioni di fresatura di sgrossatura e finiture di precisione.

Prodotto in accordo agli standard più diffusi dei mandrini macchina, con l'impiego delle bussole di riduzione RC, permette un range d'impiego da Ø 3mm a Ø 25mm, disponibili anche le pinze RC a tenuta.

Tutti i portautensili MONOforce sono equilibrati in classe G 6,3 a 15.000 giri/min.

MAX. RPM 15.000

MAX. 40 BAR



## DIN 69871 AD

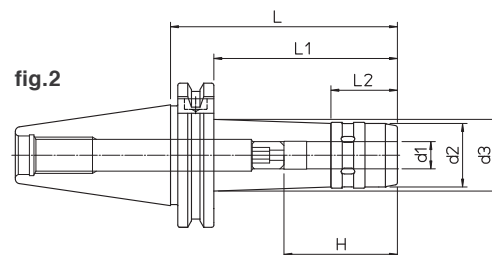
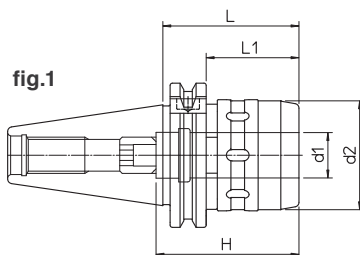

Chiave di serraggio esclusa - Predisposizione Chip

DIN	REF.	CODE	d1	d2	d3	H	L	L1	L2	kg	fig.
40	DIN69871-AD40 MF12.100	71DIN-A40MF1210	12	28	32	46	100	81	29.5	1.2	2
40	DIN69871-AD40 MF20.60	71DIN-A40MF2006	20	48	63	60	41			1.1	1
40	DIN69871-AD40 MF32.95	71DIN-A40MF3209	32	66	80	95				1.6	1
50	DIN69871-AD50 MF20.80	71DIN-A50MF2008	20	48	63	80	61			2.3	1
50	DIN69871-AD50 MF32.75	71DIN-A50MF3207	32	66	90	75	56			2.8	1

## DIN 69893 HSK-A

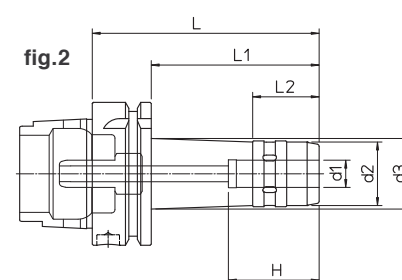
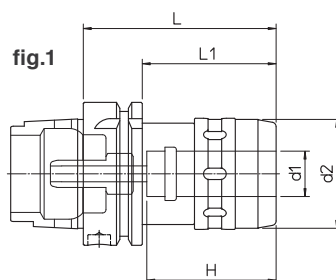

Completo di raccordo per il refrigerante - Chiave di serraggio esclusa - Predisposizione Chip

HSK-A	REF.	CODE	d1	d2	d3	H	L	L1	L2	kg	fig.
63	HSK-A63 MF12.100	71HSK-A63MF1210	12	28	32	46	100	74	29.5	1.1	2
63	HSK-A63 MF20.85	71HSK-A63MF2008	20	48	60	85	59			1.2	1
63	HSK-A63 MF32.105	71HSK-A63MF3210	32	66	80	105				2	1
100	HSK-A100 MF20.95	71HSKA100MF2009	20	48	60	95	66			2.8	1
100	HSK-A100 MF32.110	71HSKA100MF3211	32	66	80	110	81			3.1	1



# PORTAUTENSILI A FORTE SERRAGGIO

## MAS 403 BT AD

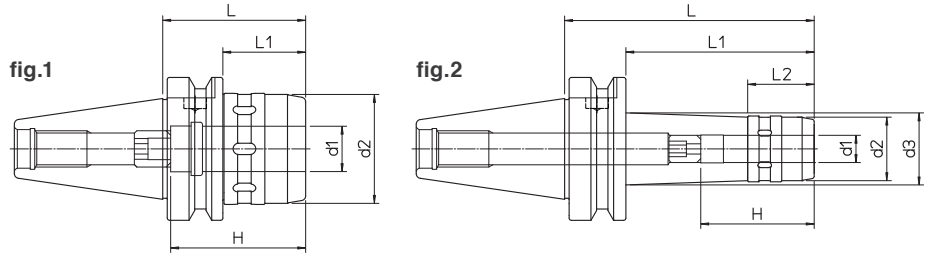

Chiave di serraggio esclusa - Predisposizione Chip

BT	REF.	CODE	d1	d2	d3	H	L	L1	L2	kg	fig.
40	MAS403 BT40-AD MF12.100	71MBT-A40MF1210	12	28	32	46	100	73	29.5	1.4	2
40	MAS403 BT40-AD MF20.65	71MBT-A40MF2007	20	48		63	65	38		1.3	1
40	MAS403 BT40-AD MF32.90	71MBT-A40MF3209	32	66		80	90			2.1	1
50	MAS403 BT50-AD MF20.85	71MBT-A50MF2008	20	48		63	85	47		3.7	1
50	MAS403 BT50-AD MF32.95	71MBT-A50MF3209	32	66		90	95	57		4.4	1

## MAS 403 BT AD FACE CONTACT

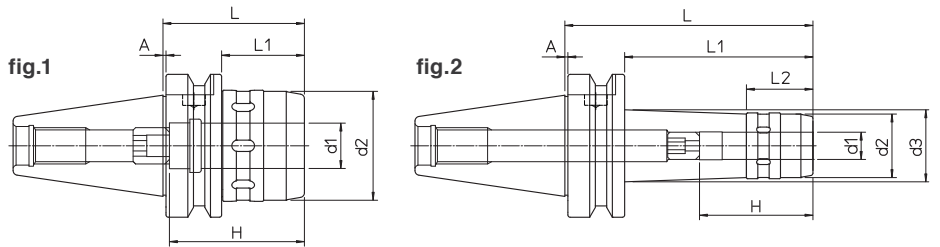

Chiave di serraggio esclusa - Predisposizione Chip

BT	REF.	CODE	d1	d2	d3	H	A	L	L1	L2	kg	fig.
40	MAS403 BT40-AD FC MF12.100	71MBF-A40MF1210	12	28	32	46	1	100	73	29.5	1.4	2
40	MAS403 BT40-AD FC MF20.65	71MBF-A40MF2007	20	48		63	1	65	38		1.3	1
40	MAS403 BT40-AD FC MF32.90	71MBF-A40MF3209	32	66		80	1	90			2.1	1
50	MAS403 BT50-AD FC MF20.85	71MBF-A50MF2008	20	48		63	1.5	85	47		3.7	1
50	MAS403 BT50-AD FC MF32.95	71MBF-A50MF3209	32	66		90	1.5	95	57		4.4	1

## RC BUSSOLE MANDRINO A FORTE SERRAGGIO

Fornibili su richiesta bussole RC a TENUTA

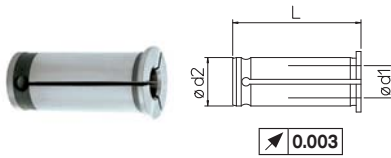

ød2	REF.	CODE	d1	L
12	RC12.03	497080012030	3	44
12	RC12.04	497080012040	4	44
12	RC12.06	497080012060	6	44
12	RC12.08	497080012080	8	44
12	RC12.10	497080012100	10	44
20	RC20.03	497080020030	3	50
20	RC20.04	497080020040	4	50
20	RC20.05	497080020050	5	50
20	RC20.06	497080020060	6	50
20	RC20.08	497080020080	8	50
20	RC20.10	497080020100	10	50
20	RC20.12	497080020120	12	50
20	RC20.14	497080020140	14	50
20	RC20.16	497080020160	16	50
32	RC32.03	497080032030	3	63
32	RC32.04	497080032040	4	63
32	RC32.05	497080032050	5	63
32	RC32.06	497080032060	6	63
32	RC32.08	497080032080	8	63
32	RC32.10	497080032100	10	63
32	RC32.12	497080032120	12	63
32	RC32.14	497080032140	14	63
32	RC32.16	497080032160	16	63
32	RC32.18	497080032180	18	63
32	RC32.20	497080032200	20	63
32	RC32.25	497080032250	25	63

## PR CT R PROLUNGHE A CALETTAMENTO TERMICO A REGOLAZIONE ASSIALE

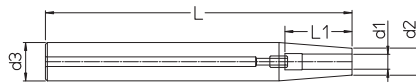

Completo di grano regolazione assiale

REF.	CODE	d1	d2	d3	L	L1	kg
PR.CT.R D20.06.130	49DC21320060	6	14	20	130	22 / 36	0.20
PR.CT.R D20.06.160	49DC21620060	6	14	20	160	22 / 32	0.33
PR.CT.R D20.08.130	49DC21320080	8	14	20	130	22 / 36	0.25
PR.CT.R D32.16.160	49DC21632160	16	27	32	160	39 / 49	0.78
PR.CT.R D32.16.200	49DC22032160	16	27	32	200	39 / 49	1.81
PR.CT.R D32.18.160	49DC21632180	18	27	32	160	39 / 49	0.77
PR.CT.R D32.20.160	49DC21632200	20	27	32	160	41 / 51	0.67
PR.CT.R D32.20.200	49DC22032200	20	27	32	200	41 / 51	0.87

**MONOd'**. Serie di portapinze integrali prodotti in accordo agli Standard ISO negli attacchi macchina DIN 69871, MAS 403 BT e DIN 69893 HSK. Prodotti in alta qualità, garantiscono un elevato grado di precisione. Tutti i portautensili ER sono equilibrati in classe G 6,3 a 15.000 giri/min.



0.003

MAX. RPM 15.000

### DIN 69871 AD PORTAPINZE - ER DIN 6499

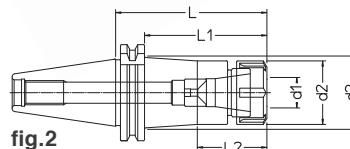
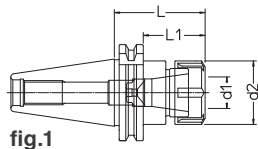

Pinze elastiche e chiavi di serraggio escluse

DIN	REF.	CODE	ER	d1	d2	d3	L	L1	L2	kg	fig.
40	DIN69871-AD40 ER16.60	71DIN-A40ER1606	16M	0.5-10	22		60	41		0.9	1
40	DIN69871-AD40 ER16.100	71DIN-A40ER1610	16M	0.5-10	22	29.5	100	81	41	1	2
40	DIN69871-AD40 ER25.60	71DIN-A40ER2506	25	1-16	42		60	41		1.1	1
40	DIN69871-AD40 ER25.100	71DIN-A40ER2510	25	1-16	42	47	100	81	46	1.6	2
40	DIN69871-AD40 ER32.70	71DIN-A40ER3207	32	2-20	50		70	51		1.2	1
40	DIN69871-AD40 ER32.110	71DIN-A40ER3211	32	2-20	50		110	91		1.7	1
50	DIN69871-AD50 ER16.100	71DIN-A50ER1610	16M	0.5-10	22	29.5	100	81	41	2.5	2
50	DIN69871-AD50 ER16.160	71DIN-A50ER1616	16M	0.5-10	22	32.5	160	141	41	3.3	2
50	DIN69871-AD50 ER25.110	71DIN-A50ER2511	25	1-16	42	48	110	91	46	2.8	2
50	DIN69871-AD50 ER25.160	71DIN-A50ER2516	25	1-16	42	50	160	141	46	3.6	2
50	DIN69871-AD50 ER32.70	71DIN-A50ER3207	32	2-20	50		70	51		2.9	1
50	DIN69871-AD50 ER32.160	71DIN-A50ER3216	32	2-20	50	57.5	160	141	52	4	2

### MAS 403 BT AD PORTAPINZE - ER DIN 6499

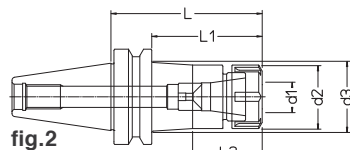
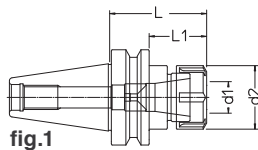

Pinze elastiche e chiavi di serraggio escluse

BT	REF.	CODE	ER	d1	d2	d3	L	L1	L2	kg	fig.
40	MAS403 BT40-AD ER16.60	71MBT-A40ER1606	16M	0.5-10	22		60	33		1	1
40	MAS403 BT40-AD ER16.100	71MBT-A40ER1610	16M	0.5-10	22	28	100	73	41	1.1	2
40	MAS403 BT40-AD ER25.65	71MBT-A40ER2506	25	1-16	42		65	38		1.2	1
40	MAS403 BT40-AD ER25.100	71MBT-A40ER2510	25	1-16	42	45.5	100	73	46	1.7	2
40	MAS403 BT40-AD ER32.70	71MBT-A40ER3207	32	2-20	50		70	43		1.3	1
40	MAS403 BT40-AD ER32.110	71MBT-A40ER3211	32	2-20	50		110	83		1.8	1
50	MAS403 BT50-AD ER16.100	71MBT-A50ER1610	16M	0.5-10	22	26.5	100	62	41	3.6	2
50	MAS403 BT50-AD ER16.160	71MBT-A50ER1616	16M	0.5-10	22	31	160	122	41	4.3	2
50	MAS403 BT50-AD ER25.110	71MBT-A50ER2511	25	1-16	42	45.5	110	72	46	3.8	2
50	MAS403 BT50-AD ER25.160	71MBT-A50ER2516	25	1-16	42	48.5	160	122	46	4.6	2
50	MAS403 BT50-AD ER32.80	71MBT-A50ER3208	32	2-20	50		80	42		3.9	1
50	MAS403 BT50-AD ER32.160	71MBT-A50ER3216	32	2-20	50	56	160	122	52	5	2

### DIN 69893 HSK-A PORTAPINZE - ER DIN 6499

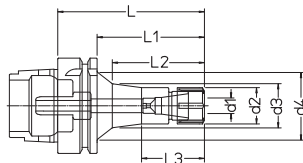

Completo di raccordo per il refrigerante

HSK-A	REF.	CODE	ER	d1	d2	d3	d4	L	L1	L2	L3	kg
63	HSK-A63 ER16.80	71HСКА063ER1608	16M	0.5-10	22	32		80	54	41		1.1
63	HSK-A63 ER16.120	71HСКА063ER1612	16M	0.5-10	22	31		120	94			1.9
63	HSK-A63 ER25.80	71HСКА063ER2508	25	1-16	42			80	54			1.3
63	HSK-A63 ER25.140	71HСКА063ER2514	25	1-16	42	47.5		140	114	46		1.7
63	HSK-A63 ER32.90	71HСКА063ER3209	32	2-20	50			90	64			1.6
63	HSK-A63 ER32.160	71HСКА063ER3216	32	2-20	50			160	134			2.2
100	HSK-A100 ER16.100	71HСКА100ER1610	16M	0.5-10	22	25	45	100	71	61	41.5	2.3
100	HSK-A100 ER16.160	71HСКА100ER1616	16M	0.5-10	22	34.5	44	160	131	126		2.5
100	HSK-A100 ER25.100	71HСКА100ER2510	25	1-16	42	45.5		100	71	47		2.6
100	HSK-A100 ER25.160	71HСКА100ER2516	25	1-16	42	49.5		160	131	47		3.2
100	HSK-A100 ER32.120	71HСКА100ER3212	32	2-20	50	55		120	91	52		3.1
100	HSK-A100 ER32.160	71HСКА100ER3216	32	2-20	50	56.5		160	131	52		3.7

## ER DIN 6499-B



0.01

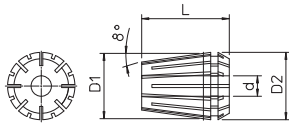

REF.	d	D1	D2	L
ER 16	0.5 ~ 10	16	17	27.5
ER 25	1 ~ 16	25	26	34
ER 32	2 ~ 20	32	33	40

RANGE	CODE ER16	CODE ER25	CODE ER32
1 - 0.5	496080116010		
1.5 - 1	496080116015		
2 - 1			
2 - 1.5	496080116021	496080125020	
2.5 - 2	496080116025		
3 - 2	496080116030	496080125030	496080132030
4 - 3	496080116040	496080125040	496080132040
5 - 4	496080116050	496080125050	496080132050
6 - 5	496080116060	496080125060	496080132060
7 - 6	496080116070	496080125070	496080132070
8 - 7	496080116080	496080125080	496080132080
9 - 8	496080116090	496080125090	496080132090
10 - 9	496080116100	496080125100	496080132100
11 - 10		496080125110	496080132110
12 - 11		496080125120	496080132120
13 - 12		496080125130	496080132130
14 - 13		496080125140	496080132140
15 - 14		496080125150	496080132150
16 - 15		496080125160	496080132160
17 - 16			496080132170
18 - 17			496080132180
19 - 18			496080132190
20 - 19			496080132200

## SET ER



REF.	Ø	CODE
SET ER16/10	0.5 ~ 10	496080116000
SET ER25/15	1 ~ 16	496080125000
SET ER32/18	2 ~ 20	496080132000

## ISO 7388/2 A - DIN 69872



fig. 1

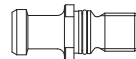
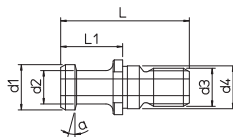

fig. 2

REF.	CODE	ISO	d1	d2	d3	d4	L	L1	a	fig.
TNT DIN69872-ISO7388/2A 40	201430250401	40	19	14	M16	17	54	26	15°	1
TNT DIN69872-ISO7388/2A 50	201430250501	50	28	21	M24	25	74	34	15°	1
TNT ISO7388/2A 40 WH	201430250400	40	19	14	M16	17	54	26	15°	2
TNT ISO7388/2A 50 WH	201430250500	50	28	21	M24	25	74	34	15°	2

## ISO 7388/2 B - ANSI B.5 50



fig. 1

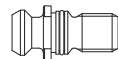
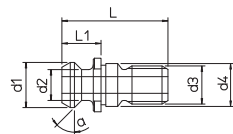
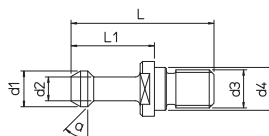

fig. 2

REF.	CODE	ISO	d1	d2	d3	d4	L	L1	a	fig.
TNT ISO7388/2B 40 ANSI B.5.50	201430251401	40	18.95	12.95	M16	17	44.50	16.40	45°	1
TNT ISO7388/2B 50 ANSI B.5.50	201430251501	50	29.10	19.60	M24	25	65.50	25.55	45°	1
TNT ISO7388/2B 40 WH	201430251400	40	18.95	12.95	M16	17	44.50	16.40	45°	2
TNT ISO7388/2B 50 WH	201430251500	50	29.10	19.60	M24	25	65.50	25.55	45°	2

## MAS 403 BT - 30° - 45°



REF.	CODE	ISO	d1	d2	d3	d4	L	L1	a
TNT MAS403 BT30 30°	201430252301	30	11	7	M12	12.5	43	23	30°
TNT MAS403 BT40 30°	201430252401	40	15	10	M16	17	60	35	30°
TNT MAS403 BT50 30°	201430252501	50	23	17	M24	25	85	45	30°
TNT MAS403 BT30 45°	201430252302	30	11	7	M12	12.5	43	23	45°
TNT MAS403 BT40 45°	201430252402	40	15	10	M16	17	60	35	45°
TNT MAS403 BT50 45°	201430252502	50	23	17	M24	25	85	45	45°



# RICAMBI MHD' - PSC

## SISTEMA MHD'

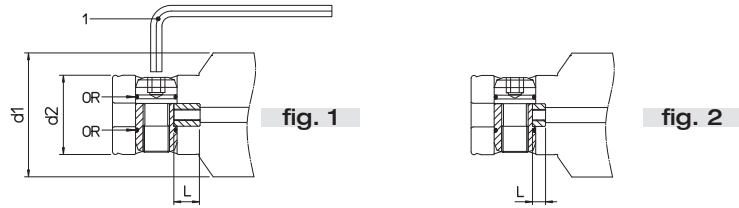

REF.	CODE	d1	d2	CODE 1	CODE OR	L	fig.
MHD' 16	381725001161	16	10	101500100250		2	2
MHD' 20	381725001201	20	13	101500100300		2.5	2
MHD' 25	381725001251	25	16	101500100300		3	2
MHD' 32	381725001321	32	20	101500100400	101254007510	3.55	2
MHD' 40	381725001401	40	25	101500100500	101254010010	4	2
MHD' 50 RD 50 / .. TRM - TRC - TR-E	381725001501	50	32	101500100600	101254013010	4.2	2
MHD' 50	381725001001	50	32	101500100600	101254013010	12.2	1
MHD' 63-80 RD 63 / .. TRM - TRC	381725001502	63-80	42	101500100800	101251002075	4.9	2
MHD' 63-80	381725001002	63-80	42	101500100800	101251002075	13.85	1

## MHD' - PSC / TS

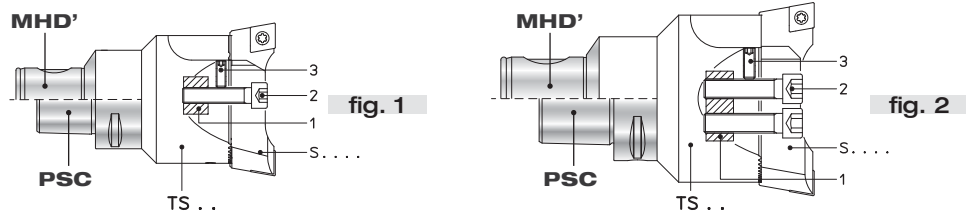

REF.	CODE 1	CODE 2	CODE 3	fig.
TS 16/16 MHD'	201430110008	100051030014	100231030004	1
TS 20/20 MHD'	201430110009	100051040015	100231030005	1
TS 25/25 MHD'	201430110032	100051040020	100231030008	1
TS 32/32 MHD'	201430110031	100051050025	100231040012	1
TS 40/40 MHD'	201430110029	100051060030	100231050014	1
TS 50/50 MHD' - PSC50-TS50 / PSC63-TS50	201430110013	100051080035	100231050012	1-2
TS 50/63 MHD'	201430110030	100051100040	100231060016	2
TS 63/63 MHD' - PSC63-TS63	201430110030	100051100040	100231060016	1-2
TS 80/80 MHD' - PSC63-TS80	201430110015	100051120045	100231080025	1-2
TS 80/90 MHD'	201430110015	100051120045	100231080025	1-2

## TRC

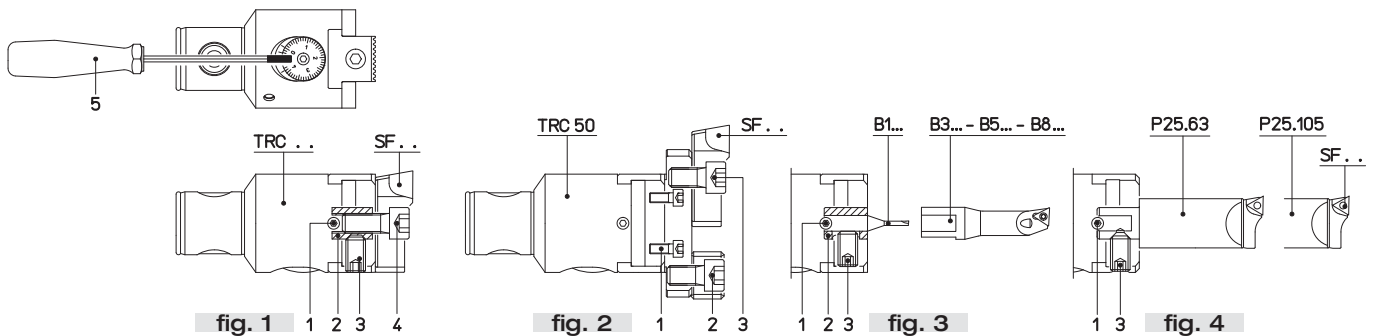

REF.	CODE 1	CODE 2	CODE 3	CODE 4	CODE 5	fig.
TRC 16	200100190301			100051030006	101500800150	1
TRC 20	200100190301			100051040008	101500800150	1
TRC 25	100271040004			100051050010	101500800150	1
TRC 32	100271050005			100051060012	101500800250	1
TRC 40	100271060006			100051080014	101500800300	1
TRC 50	100271060008	201041015002	100231100016	100051100025	101500800300	1
TRC 50	200100150501	100051100020	100051100020		101500800300	2
TRC 50	100271060008	200560116082	100231100010		101500800300	3-4
TRC 63	100271060008			100051100020	101500800300	1
TRC 80	100271060012			100051100025	101500800300	1

**MHD' - PSC / TRM**

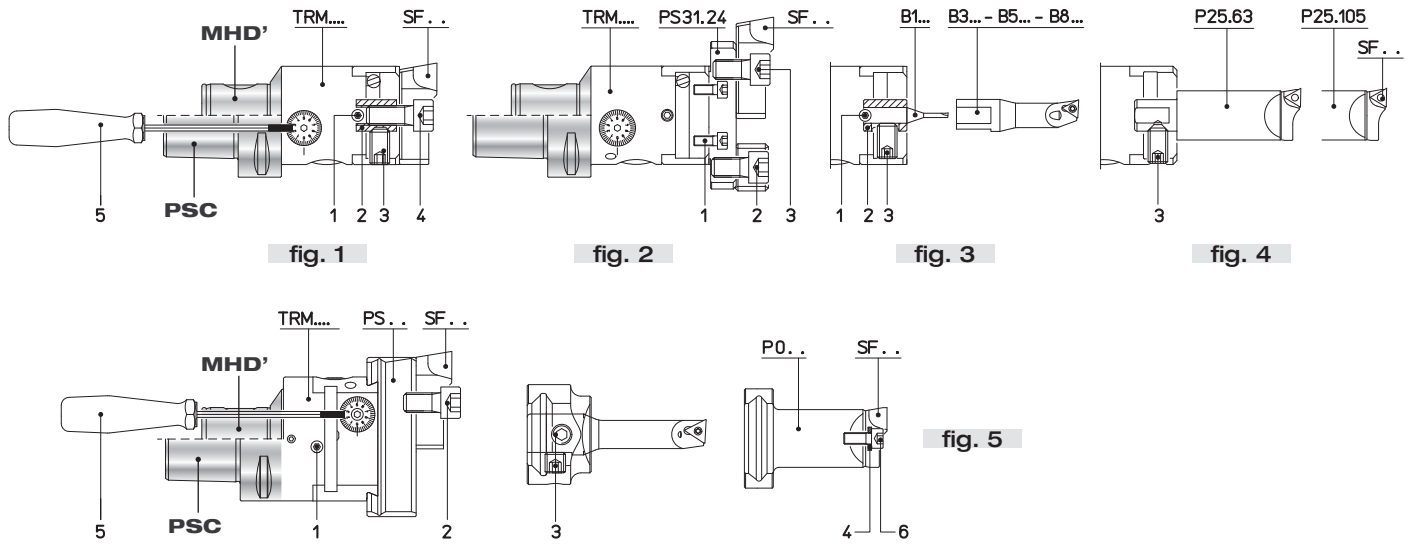

REF.	CODE 1	CODE 2	CODE 3	CODE 4	CODE 5	CODE 6	fig.
TRM 16 MHD'	200100190301			100051030006	101500800150		1
TRM 20 MHD'	200100190301			100051040008	101500800150		1
TRM 25 MHD'	100271040004			100051050010	101500800200		1
TRM 32 MHD'	100231040006			100051060012	101500800200		1
TRM 40 MHD'	100271050005			100051080014	101500800250		1
TRM 50 MHD' PSC50-TRM50 PSC63-TRM50	100271050008	201041015002	100231100016	100051100025	101500800250		1
TRM 50 MHD' PSC50-TRM50 PSC63-TRM50	200100150501	100051100020	100051100020		101500800250		2
TRM 50 MHD' PSC50-TRM50 PSC63-TRM50	100271050008	200560116082	100231100016		101500800250		3-4
TRM 63 MHD' PSC63-TRM63	100251060010	100051100018	100251080008	100051050012	101500800300	100800100530	5
TRM 80-MHD' PSC63-TRM80	100251060014	100051100018	100251080008	100051050012	101500800300	100800100530	5
TRM 125 MHD'	100251060020	100051100025		100051060018	101500800300	100800100640	5

**TRE 50**

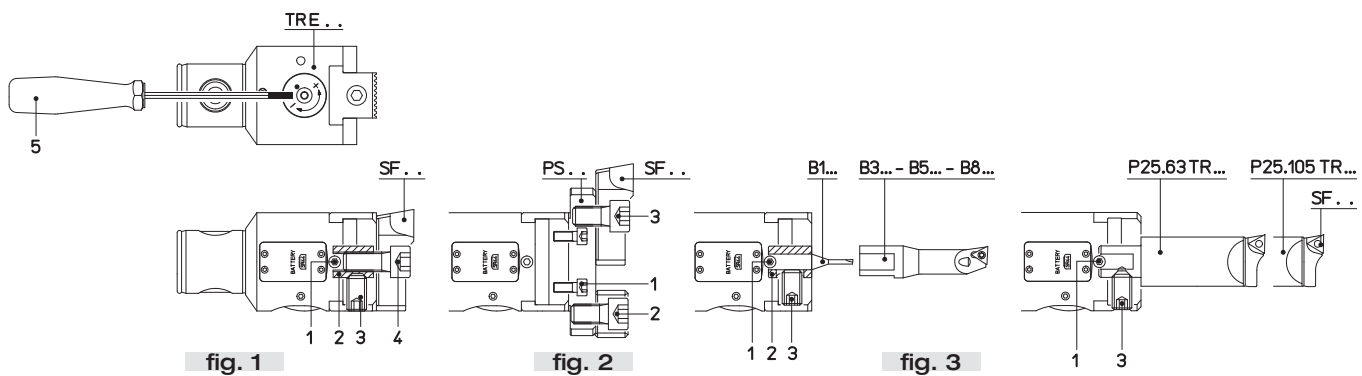

REF.	CODE 1	CODE 2	CODE 3	CODE 4	CODE 5	fig.
TRE 50	100238060010	201041015002	100231100016	100051100025	101500800250	1
TRE 50	200100150501	100051100020	100051100020			2
TRE 50	100238060010	200560116082	100231100016			3

# RICAMBI MHD' - PSC - MONOd

## PE - MHD' ER DIN 6499

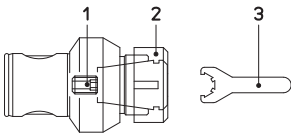

REF.	CODE 1	CODE 2	CODE 3
PE 20 / ER16M	200100190403	100451011600	101501001600
PE 32 / ER25M	200100190608	100451012500	101501002500
PE 40 / ER25	200100190808	100451032500	101501002501
PE 50 / ER25	200100190808	100451032500	101501002501
PE 50 / ER32	200100190808	100451033200	101501003201
PE 63 / ER32	200100191014	100451033200	101501003201

## PE - PSC / MONOd ER DIN 6499

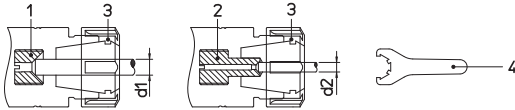

REF.	CODE 1	d1	CODE 2	d2	CODE 3	CODE 4
ER 16 M	201082010001	5 ~ 10	201082010002	1 ~ 4	100451011600	101501001600
ER 25	201082018001	8 ~ 16	201082018002	2 ~ 7	100451032500	101501002501
ER 32	201082022001	8 ~ 20	201082022002	3 ~ 7	100451033200	101501003201

## AW DIN 1835 B-E

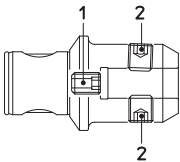

REF.	CODE 1	CODE 2
AW 50/6	200100190808	200100190610
AW 50/8	200100190808	200100190810
AW 50/10	200100190809	200100191012
AW 50/12	200100190809	200100191216
AW 50/14	200100190809	200100191216
AW 50/16	200100191215	200100191416
AW 50/20	200100191215	200100191616
AW 50/25	200100191615	200100191820
AW 63/16	200100191215	200100191416
AW 63/20	200100191215	200100191616
AW 63/25	200100191615	200100191820
AW 63/32	200100191615	200100192020
AW 80/40	200100192019	200100192020

## PF MHD' - PSC

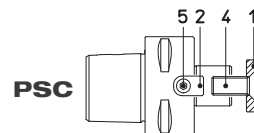
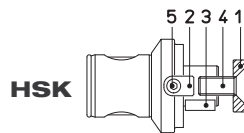

REF.	CODE 1	CODE 2	CODE 3	CODE 4	CODE 5
PF 40/16	201010085010	201101800801	101001040014	100101080025	100051030008
PF 40/22	201010105030	201101801002	101001060016	100101100025	100051040010
PF 50/16	201010085010	201101800801	101001040014	100101080025	100051030008
PF 50/22 MHD' / PSC50-PF22.25	201010105030	201101801002	101001060016	100101100025	100051040010
PF 50/27 MHD' / PSC50-PF27.25	201010125030	201101801202	101001070018	100101120030	100051050012
PF 50/32	201010165020	201101801402	101001080020	100101160035	100051060016
PF 63/22	201010105030	201101801002	101001060016	100101100025	100051040010
PF 63/27 MHD' / PSC63-PF27.25	201010125030	201101801202	101001070018	100101120030	100051050012
PF 63/32 MHD' / PSC63-PF32.25	201010165020	201101801402	101001080020	100101160035	100051060016
PF 80/32 MHD' / PSC80-PF32.30	201010165020	201101801402	101001080020	100101160035	100051060016
PF 80/40 MHD' / PSC80-PF40.45	201010210010	201101801603	101001100025	100101200045	100051060018
PF 80/50	201010260330	201101801802	101001120028	100101240050	100051060020
PF 80/60		201101802510	101001140036		100051120025

## PSC

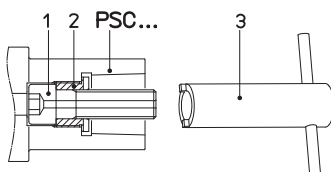

PSC	CODE 1	CODE 2	CODE 3
40	200101151448	201032215005	101501402101
50	200101151658	201032515005	101501402401
63	200101152071	201033015021	101501403001
80	200101152071	201033015021	101501403001

**PSC - TU ISO 26623-1**

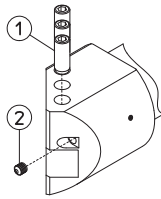

REF.	CODE 1	CODE 2
TCD' PSC 50 TU20.45R/L	100231120025	100585010800
TCD' PSC 63 TU25.45R/L	100231120025	100585010800
TCD' PSC 80 TU32.45R/L	100231120025	100585010800

**PSC - TU ISO 26623-1**

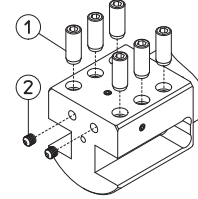

REF.	CODE 1	CODE 2
TCD' PSC 50 TU20.02	100231120025	100585010800
TCD' PSC 63 TU25.02	100231120025	100585010800
TCD' PSC 80 TU32.02	100231120025	100585010800

**PSC - D... ISO 26623-1**

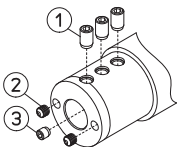

REF.	CODE 1	CODE 2	CODE 3
TCD' PSC 50 D.25x80	100231100016	100585010800	
TCD' PSC 63 D.25x80	100231100016	100585010800	
TCD' PSC 63 D.40x125	100231120020	100585010800	100231080008
TCD' PSC 80 D.25x85	100231100016	100585010800	
TCD' PSC 80 D.40x125	100231120020	100585010800	100231080008

**PSC - TU ISO 26623-1**

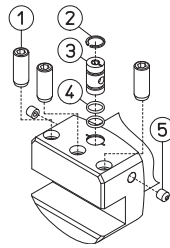

REF.	CODE 1	CODE 2	CODE 3	CODE 4	CODE 5
TCD' PSC 63 TU20.90	100231120025	100900301400	201462501400	101251002043	100580610180
TCD' PSC 63 TU25.90	100231120025	100900301400	201462501400	101251002043	100580610180
TCD' PSC 80 TU32.90	100231120025	100900301400	201462501400	101251002043	100580610180

**SS.. 95**

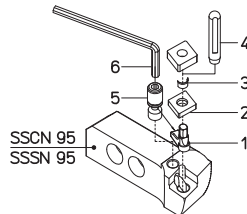

REF.	CODE 1	CODE 2	CODE 3	CODE 4	CODE 5	CODE 6
SSCN 95	491111190600	492031190600	100655095112	101501301408	494311190600	101500100400
SSSN 95	491111190600	492035190600	100655095112	101501301408	494311190600	101500100400

**HSK**

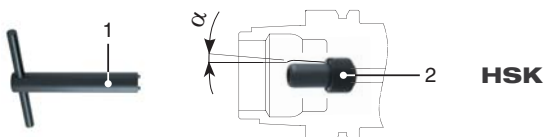

REF.	CODE 1	CODE 2	$\alpha$
HSK-A50	101501101400	382019010001	$\pm 1^\circ$
HSK-A63	101501101600	382019012001	$\pm 1^\circ$
HSK-A80	101501101800	382019014001	$\pm 1^\circ$
HSK-A100	101501102200	382019016001	$\pm 1^\circ$

**PSC**

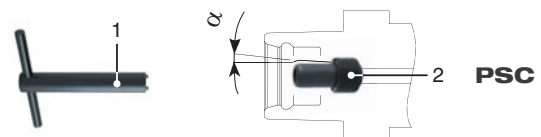

REF.	CODE 1	CODE 2	$\alpha$
PSC 40	101501200700	382020006001	$\pm 1^\circ$
PSC 50	101501200800	382020007001	$\pm 1^\circ$
PSC 63	101501200900	382020008001	$\pm 1^\circ$
PSC 80	101501201100	382020010001	$\pm 1^\circ$

## FORCE GH - VT DISPOSITIVI A TENUTA PER REFRIGERANTE AD ALTA PRESSIONE

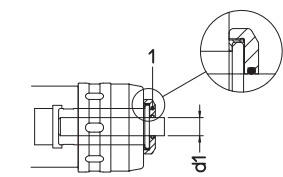

fig. 1

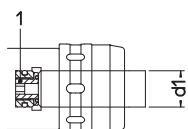

fig. 2

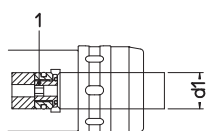
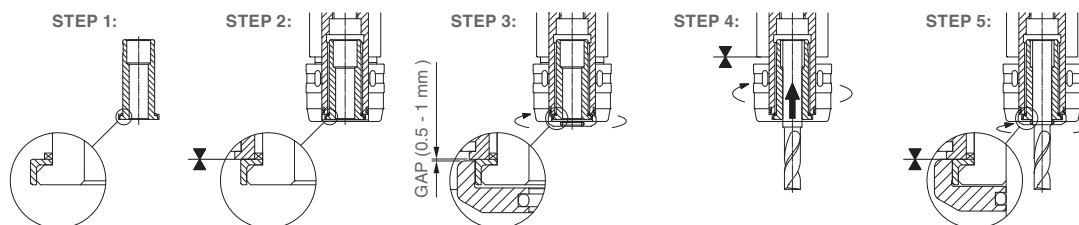

fig. 3

fig.	REF.	CODE 1	d1
1	GH 20 MONOforce 20 HSK63 MHD'50 / DIN/BT-40-50 PSC 63 - 80	382042020061	6
		382042020081	8
		382042020101	10
		382042020121	12
		382042020141	14
	382042020161	16	
2	VT 20.20 MONOforce 20 DIN/BT-40-50 HSK63-100 PSC 63-80	382042020201	20
1	GH 32 MONOforce 32 DIN/BT-40-50 / HSK63-100 MHD'63 PSC 63-80	382042032061	6
		382042032081	8
		382042032101	10
		382042032121	12
		382042032141	14
		382042032161	16
		382042032181	18
	382042032201	20	
	382042032251	25	
2	VT 32.32 MONOforce 32 DIN/BT-40 HSK63-100 PSC 63-80	382042032321	32
3	VT 32.32.100 MONOforce 32 DIN/BT-50	382042032322	32



## FORCE VCR VITE REGOLAZIONE CON PASSAGGIO REFRIGERANTE

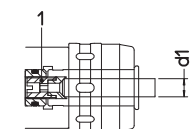

fig. 1

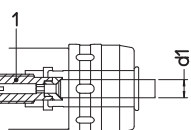
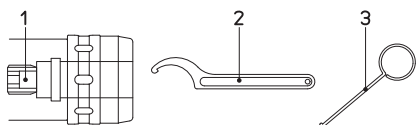

fig. 2

fig.	REF.	CODE 1	d1
1	VCR 20 MONOforce 20 HSK63-100 MHD'50 PSC 63-80	382041020032	3 ~ 5
		382041020062	6 ~ 12
		382041020142	14 ~ 20
	382041032033	3 ~ 5	
1	VCR 32 MONOforce 32 HSK63-100 MHD'63 PSC 63-80	382041032063	6 ~ 12
		382041032143	14 ~ 20
		382041032253	25 ~ 32
	382041020031	3 ~ 5	
2	VCR 20 MONOforce 20 DIN/BT-40-50	382041020061	6 ~ 12
		382041020141	14 ~ 20
		382041032031	3 ~ 5
2	VCR 32 MONOforce 32 DIN/BT-40	382041032061	6 ~ 12
		382041032141	14 ~ 20
		382041032251	25 ~ 32
	382041032032	3 ~ 5	
2	VCR 32 MONOforce 32 DIN/BT-50	382041032062	6 ~ 12
		382041032142	14 ~ 20
		382041032252	25 ~ 32

## FORCE



REF	CODE 1	CODE 2	CODE 3
FORCE 12	200100191014	101500400028	201271600400
FORCE 20	200100191615	101500400050	201271600400
FORCE 32	200100191615	101500400075	201271600400

**BHT 250 - 500 SG**  
SGROSSATURA

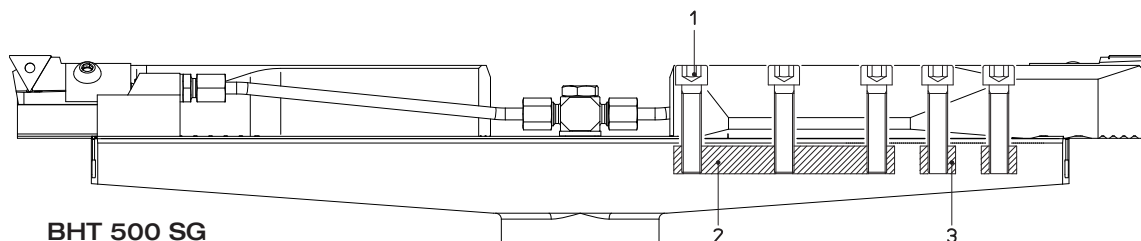
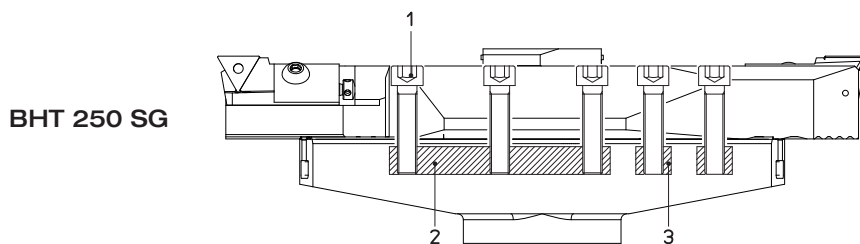

REF.	CODE 1	CODE 2	CODE 3
BHT 250 SG	100051100045	201430100065	201430100066
BHT 500 SG	100051100045	201430100065	201430100066

**BHT 250 - 500 FN**  
FINITURA

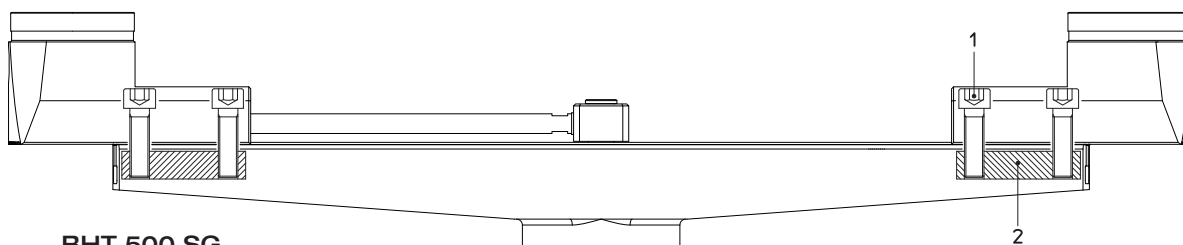
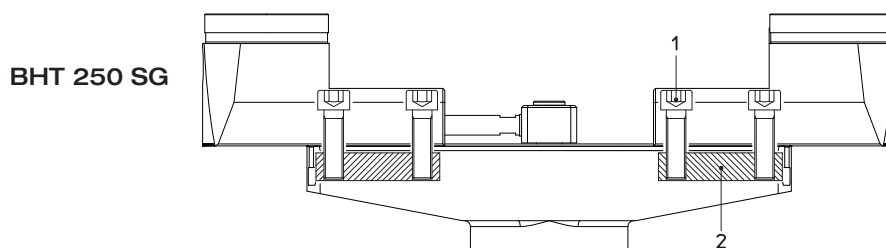

REF.	CODE 1	CODE 2
BHT 250 SG	100051100035	201430100067
BHT 500 SG	100051100035	201430100067

# DATI TECNICI DATI DI TAGLIO

## DATI DI TAGLIO CONSIGLIATI PER SGROSSATURA DI FORI CON TESTINE BITAGLIENTI TS

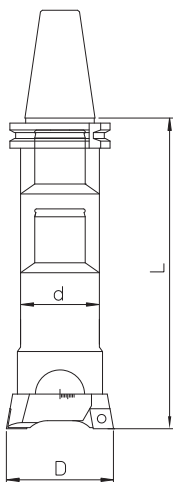

materiale	dimensioni barenò	condizioni di lavoro	velocità di taglio Vc = m/min. diametro			avanzamento f = mm/giro (due taglienti) raggio inserto		
			D < 38	D = 38-120	D > 120	R = 0.2	R = 0.4	R = 0.8
acciaio al carbonio HB ≤ 200	L / d = 2.5	buona	120 - 180	140 - 200	160 - 250		0.2 - 0.4	0.3 - 0.5
	L / d = 4	normale	100 - 160	120 - 180	140 - 200		0.2 - 0.4	0.3 - 0.5
	L / d = 6.3	difficile	70 - 100	70 - 100	70 - 100	0.15 - 0.3	0.2 - 0.4	
acciaio al carbonio HB > 200	L / d = 2.5	buona	100 - 160	120 - 180	140 - 200		0.2 - 0.4	0.3 - 0.5
	L / d = 4	normale	80 - 140	100 - 160	120 - 180		0.2 - 0.4	0.3 - 0.5
	L / d = 6.3	difficile	60 - 90	70 - 100	70 - 100	0.15 - 0.3	0.2 - 0.4	
acciaio inox AISI 304 - 316	L / d = 2.5	buona	80 - 110	90 - 120	100 - 140		0.2 - 0.4	0.3 - 0.5
	L / d = 4	normale	70 - 100	80 - 110	90 - 120		0.2 - 0.4	0.3 - 0.5
	L / d = 6.3	difficile	60 - 90	60 - 90	60 - 90	0.15 - 0.3	0.2 - 0.4	
ghisa	L / d = 2.5	buona	90 - 120	100 - 140	120 - 160		0.2 - 0.4	0.3 - 0.5
	L / d = 4	normale	70 - 100	90 - 120	100 - 140		0.2 - 0.4	0.3 - 0.5
	L / d = 6.3	difficile	60 - 90	60 - 90	60 - 90	0.15 - 0.3	0.2 - 0.4	
alluminio	L / d = 2.5	buona	160 - 250	200 - 300	250 - 350		0.3 - 0.5	0.4 - 0.6
	L / d = 4	normale	140 - 200	160 - 250	200 - 300		0.3 - 0.5	0.4 - 0.6
	L / d = 6.3	difficile	100 - 150	100 - 150	100 - 150	0.2 - 0.4	0.3 - 0.5	

profondità di passata ap = mm	campo di lavoro Ø = mm	max. profondità di passata	
		acciaio	ghisa, alluminio
18 - 28	18 - 28	1.5 - 2	2 - 2.5
28 - 50	28 - 50	2 - 3	2.5 - 3.5
50 - 68	50 - 68	3 - 4	3.5 - 5
68 - 200	68 - 200	4 - 5	5 - 7
200 - 500	200 - 500	5 - 6	6 - 8

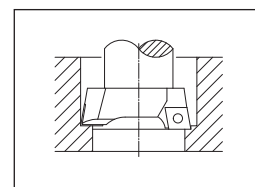
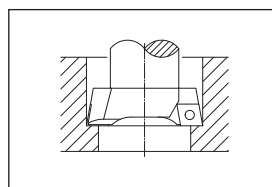
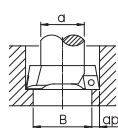

Due taglienti sullo stesso diametro

Due taglienti su diametri diversi

È consigliabile che il preforo B sia ≥ al diametro del barenò d.

## DATI DI TAGLIO CONSIGLIATI PER L'ALESATURA CON TESTAROSSA TRM / TRC / TR-E

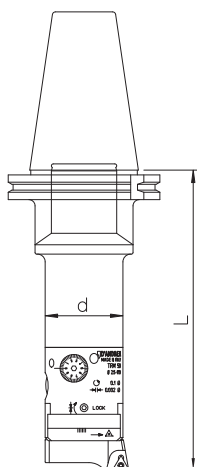

materiale	dimensioni barenò	condizioni di lavoro	velocità di taglio Vc = m/min.	avanzamento fn = mm/giro raggio inserto			qualità inserto	profondità di passata
				R = 0.0	R = 0.2	R = 0.4		
acciaio al carbonio HB ≤ 200	L / d = 2.5	buona	200 - 300		0.05 - 0.08	0.07 - 0.1	DC100 DP300	 0.1 - 0.25 mm
	L / d = 4	normale	160 - 250		0.05 - 0.08	0.07 - 0.1		
	L / d = 6.3	difficile	70 - 100	0.05 - 0.08	0.05 - 0.08			
acciaio al carbonio HB > 200	L / d = 2.5	buona	160 - 250		0.05 - 0.08	0.07 - 0.1	DC100	
	L / d = 4	normale	150 - 200		0.05 - 0.08	0.07 - 0.1		
	L / d = 6.3	difficile	70 - 100	0.05 - 0.08	0.05 - 0.08			
acciaio inox AISI 304 - 316	L / d = 2.5	buona	120 - 160		0.05 - 0.08	0.07 - 0.1	DP300	
	L / d = 4	normale	100 - 140		0.05 - 0.08	0.07 - 0.1		
	L / d = 6.3	difficile	70 - 100	0.05 - 0.08	0.05 - 0.08			
ghisa	L / d = 2.5	buona	120 - 160		0.05 - 0.08	0.07 - 0.1	DK100 DP100	
	L / d = 4	normale	100 - 140		0.05 - 0.08	0.07 - 0.1		
	L / d = 6.3	difficile	70 - 100	0.05 - 0.08	0.05 - 0.08			
alluminio	L / d = 2.5	buona	300 - 400		0.05 - 0.08	0.07 - 0.1	DK100	
	L / d = 4	normale	250 - 350		0.05 - 0.08	0.07 - 0.1		
	L / d = 6.3	difficile	100 - 150	0.05 - 0.08	0.05 - 0.08			
acciaio HB > 200	L / d = 2.5	buona	80 - 100		0.04 - 0.06	0.05 - 0.07	D20CBN	
	L / d = 4	normale	80 - 100		0.04 - 0.06	0.05 - 0.07		

### FORMULA DI CALCOLO PER ALESATURA

Vc velocità di taglio (m/min.)

D diametro del pezzo da lavorare (mm)

n numero di giri al minuto (giri/min.)

Vf velocità avanzamento (mm/min.)

fn avanzamento al giro (mm/giro)

π 3.14

$$Vc = \frac{\pi \cdot D \cdot n}{1000}$$

$$n = \frac{Vc \cdot 1000}{\pi \cdot D}$$

$$Vf = n \cdot fn$$

# DATI TECNICI NORME ATTACCHI BASE

## HSK-A

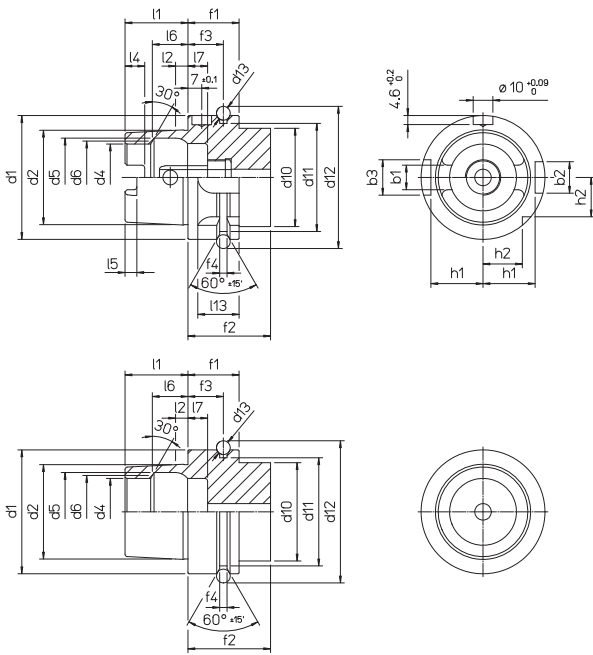

HSK	32	40	50	63	80	100
b1 <sup>+0.04</sup> <sub>-0.04</sub>	7.05	8.05	10.54	12.54	16.04	20.02
b2 H10	7	9	12	16	18	20
b3 H10	9	11	14	18	20	22
d1 h10	32	40	50	63	80	100
d2	24.007	30.007	38.009	48.010	60.012	75.013
d4 H10	17	21	26	34	42	53
d5 H11	20.5	25.5	32	40	50	63
d6	19	23	29	37	46	58
d10 max.	26	34	42	53	68	88
d11 <sup>0</sup> <sub>-0.1</sub>	26.5	34.8	43	55	70	92
d12 <sup>0</sup> <sub>-0.1</sub>	37	45	59.3	72.3	88.8	109.75
d13	4		7			
f1 <sup>0</sup> <sub>-0.1</sub>	20		26		29	
f2 min.	35		42		45	
f3 ± 0.1	16		18		20	
f4 <sup>+0.15</sup> <sub>0</sub>	2		3.75			
h1 <sup>0</sup> <sub>-0.2</sub>	13	17	21	26.5	34	44
h2 <sup>0</sup> <sub>-0.3</sub>	9.5	12	15.5	20	25	31.5
l1 <sup>0</sup> <sub>-0.2</sub>	16	20	25	32	40	50
l2	3.2	4	5	6.3	8	10
l4 <sup>+0.2</sup> <sub>0</sub>	5	6	7.5	10	12	15
l5 <sup>+0.2</sup> <sub>0</sub>	3	3.5	4.5	6	8	10
l6 JS10	8.92	11.42	14.13	18.13	22.85	28.56
l7 <sup>0</sup> <sub>-0.1</sub>	8		10		12.5	
l13	12		19		24	

## DIN 69871 A ( ISO 7388-1 )

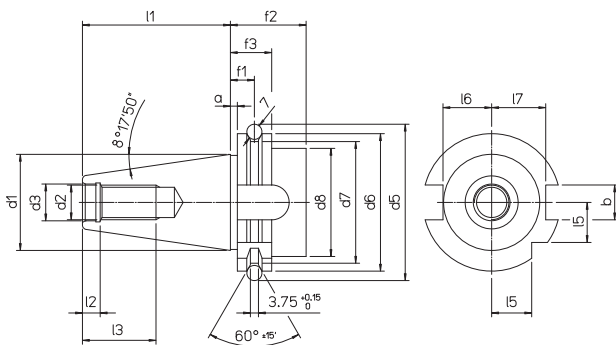

ISO	30	40	45	50	60
a ± 0.1	3.2				
b +0.5/0	16.1		19.3	25.7	
d1	31.75	44.45	57.15	69.85	107.95
d2 6H	M12	M16	M20	M24	M30
d3 H7	13	17	21	25	32
d5 ± 0.05	59.3	72.3	91.35	107.25	164.75
d6 0/-0.1	50	63.55	82.55	97.50	155
d7 0/-0.5	44.3	56.25	75.25	91.25	147.70
d8 max.	45	50	63	80	130
f1 ± 0.1	11.1				
f2 min.	35				38
f3 0/-0.1	19.1				
l1 0/-0.3	47.8	68.4	82.7	101.75	161.90
l2 +0.5/0	5.5	8.2	10	11.5	14
l3 min.	24	32	40	47	59
l5 0/-0.3	15	18.5	24	30	49
l6 0/-0.3	16.4	22.8	29.1	35.5	54.5
l7 0/-0.3	19	25	31.3	37.7	59.3

## MAS 403 BT A

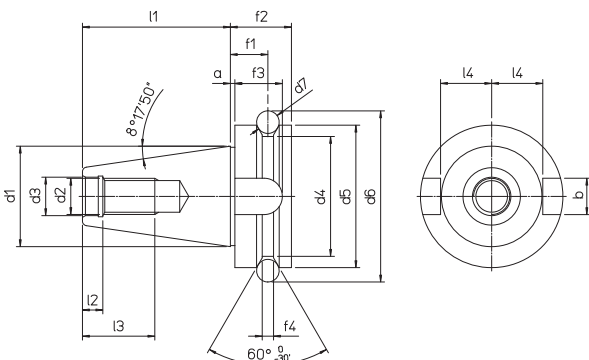

ISO	30	35	40	45	50	60
a ± 0.4	2		3			
b +0.2/0	16.1		19.3	25.7	25.7	
d1	31.75	38.10	44.45	57.15	69.85	107.95
d2 6H	M 12		M 16	M 20	M 24	M 30
d3 H8	12.5		17	21	25	31
d4 0/-0.5	38	43	53	73	85	135
d5 h8	46	53	63	85	100	155
d6 ± 0.05	56.03	65.68	75.56	100.09	118.89	180.22
d7	8	10		12	15	20
f1 ± 0.1	13.6	14.6	16.6	21.2	23.2	28.2
f2	22	24	27	33	38	48
f3 min.	17	20	21	26	31	34
f4	4	5		6	7	11
l1 ± 0.2	48.4	56.4	65.4	82.8	101.8	161.8
l2 +0.5/0	7		9	11	13	16
l3 min.	24		30	36	45	56
l4 0/-0.3	16.3	19.6	22.6	29.1	35.4	60.1



# DATI TECNICI NORME ATTACCHI BASE

## ANSI/CAT

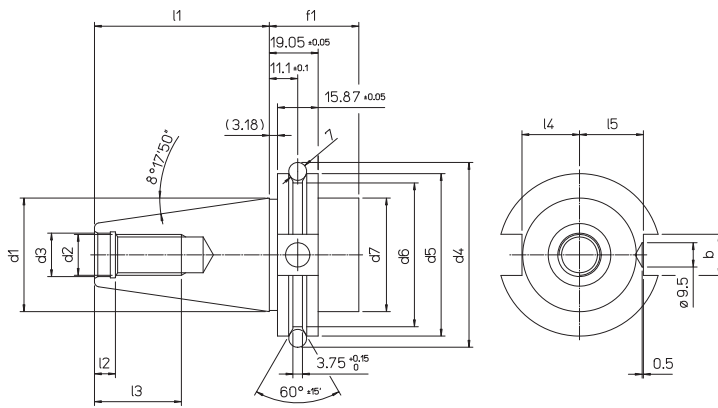

ISO	40	45	50
b +0.2 / 0	16.1	19.3	25.7
d1 6H	44.45	57.15	69.85
d2	M 16	M 20	M 24
d3 H7	17	21	25
d4 ±0.05	72.3	91.35	108.25
d5 0 / -0.1	63.55	82.55	98.5
d6 0 / -0.5	56.25	75.25	91.25
d7 ±0.15	44.45	57.15	69.95
f1 min	35		38
l1 0 / -0.3	68.4	82.7	101.75
l2 +0.5 / 0	8.2	10	11.5
l3 min.	32	40	47
l4 0 / -0.3	22.8	29.10	35.50
l5 0 / -0.3	25	31.3	37.7

## DIN 2080

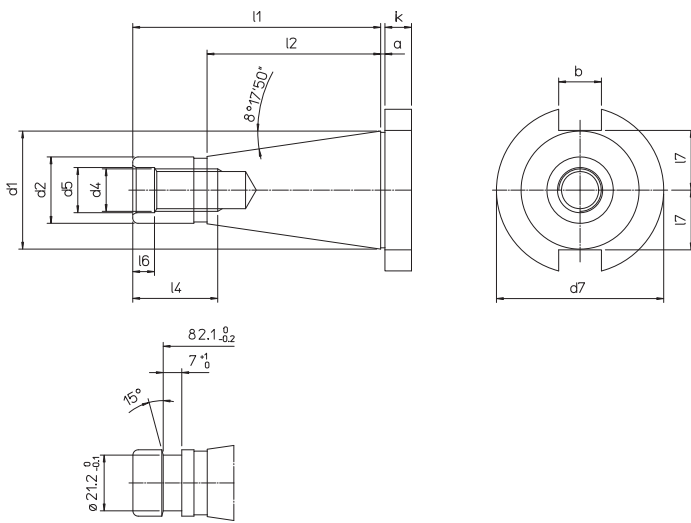

ISO 40 OTT

ISO	30	40	45	50
a ±0.2	1.6		3.2	
b H12	16.1		19.3	25.7
d1	31.75	44.45	57.15	69.85
d2 a10	17.4	25.3	32.4	39.6
d4 ±0.05	M 12	M 16	M 20	M 24
d5	13	17	21	26
d7 0 / -0.4	50	63	80	97.5
k ±0.15	8	10	12	12
l1	68.4	93.4	106.8	126.8
l2	48.4	65.4	82.8	101.8
l4	24	32	40	47
l6 +0.5 / 0	5.5	8.2	10	11.5
l7 max.	16.2	22.5	29	35.3

## ISO 26623-1

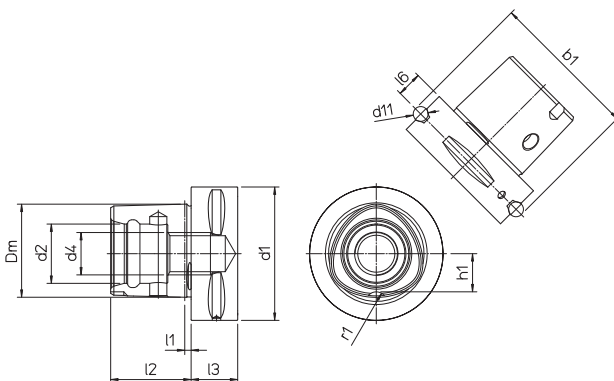

PSC	40	50	63	80
b1 ±0.1	46	59.3	70.7	86
Dm	28	35	44	55
d1 ±0.1	40	50	63	80
d2 +0.1 / -0.05	18	21	28	32
d4	M14x1.5	M16x1.5	M20x2	
d11	5	7		
l1	2.5	3		
l2 ±0.1	24	30	38	48
l3 min	20		22	30
l6 ±0.15	8	10	12	
h1 ±0.1	11	14	18	22.2
r1 ±0.3	4	5	6	7

## ISO 26623-2

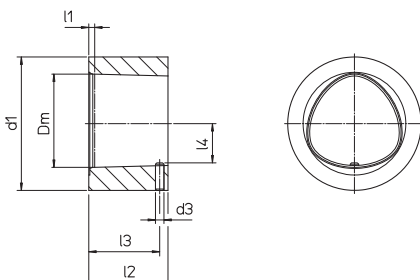

PSC	40	50	63	80
Dm	28	35	44	55
d1 min	40	50	63	80
d3	2.5	3	4	5
l1	2.3	2.8	2.8	2.8
l2 ±0.1	23.4	29.4	37.4	47.4
l3 ±0.2	21	26	33.5	43
l4	11.5 ±0.2	14.5 ±0.2	18.5 ±0.2	22.8 ±0.2

Generatore grafico che permette di comporre in breve tempo utensili completi con elementi del MODULHARD'ANDREA, indicando le dimensioni, il peso e la lista dei componenti.

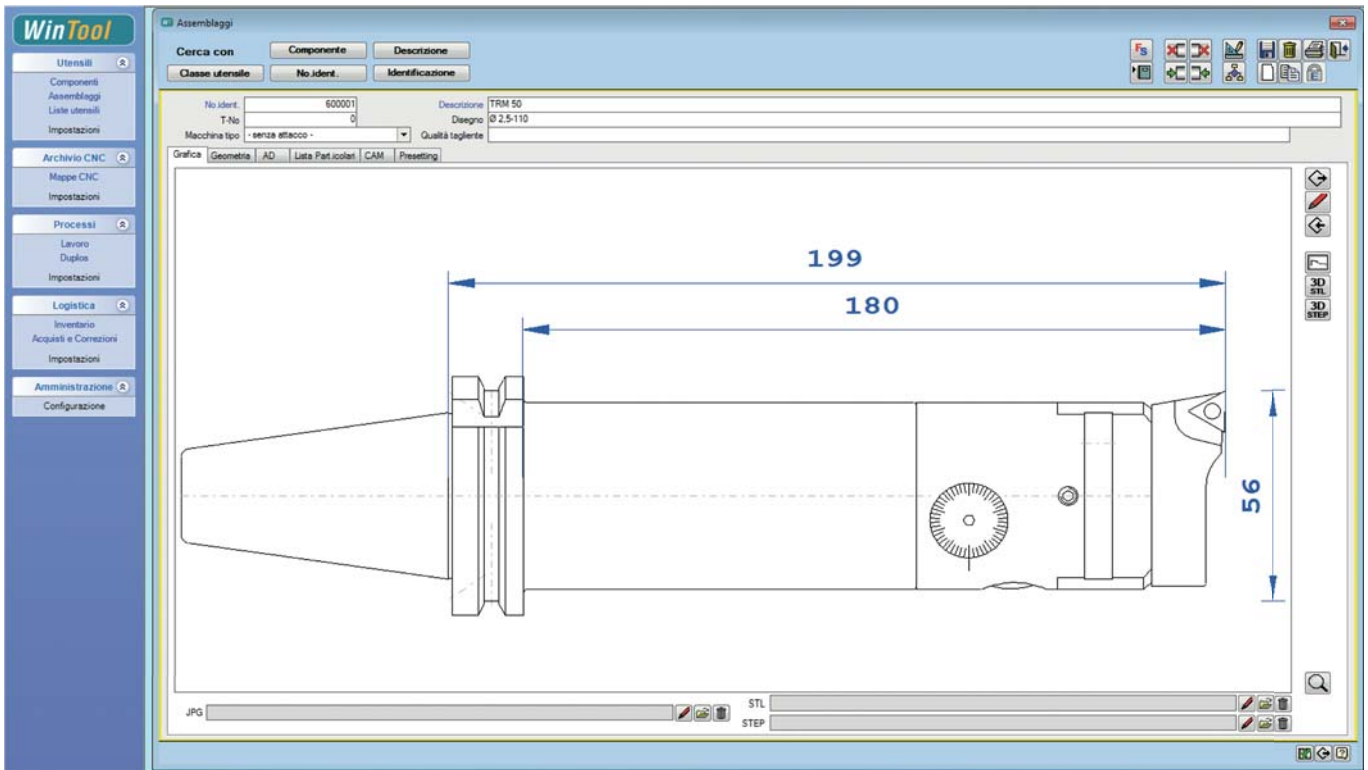

**Scheda Utensile**

TRM 50      600001      Diametro parte pezzo 56,00  
 Ø 2,5-110

Descrizione / Tipo	Design / Item No / Product Code / Storage Location	Peso
1 DIN69871-AD+B40 FC MHD50.120	MHD 50 41.8.50.01.040.28F Ø 2,5-110	1,70
1 TRM 50	45.50.050.0050.0	1,00
1 SFTP 50	TPGX 1103 ... L 47.050.05.50.001	0,08
1 TPGX 110300L-10	DC 100T TPGX 110300L C10T	0,00
		<b>2,780</b>

# INSERTI

## WCGT ○○○○○○L

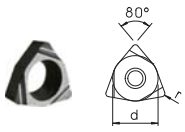

REF.		CODE	d	s	r	⌘	🔑
WCGT 020102L DC 100	CERMET	WCGT020102LC100	3.97	1.59	0.2	TS 21* - TS 211*	TORX T06
WCGT 020102L DC 100T	CERMET RIVESTITO	WCGT020102LC10T	3.97	1.59	0.2	TS 21* - TS 211*	TORX T06
WCGT 020102L DK 100	METALLO DURO	WCGT020102LK100	3.97	1.59	0.2	TS 21* - TS 211*	TORX T06
WCGT 020102L DP 300	METALLO DURO	WCGT020102LP300	3.97	1.59	0.2	TS 21* - TS 211*	TORX T06
WCGT 020104L DC 100	CERMET	WCGT020104LC100	3.97	1.59	0.2	TS 21* - TS 211*	TORX T06
WCGT 020104L DC 100T	CERMET RIVESTITO	WCGT020104LC10T	3.97	1.59	0.4	TS 21* - TS 211*	TORX T06
WCGT 020104L DK 100	METALLO DURO	WCGT020104LK100	3.97	1.59	0.4	TS 21* - TS 211*	TORX T06
WCGT 020104L DP 300	METALLO DURO	WCGT020104LP300	3.97	1.59	0.4	TS 21* - TS 211*	TORX T06

\* TS21 : B...06 / \* TS211 : B...08

## CCGT ○○○○○○L

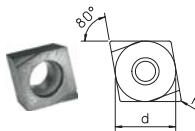

REF.		CODE	d	s	r	⌘	🔑
CCGT 060200L DC 100	CERMET	CCGT060200LC100	6.35	2.38	0	TS 25	TORX T08
CCGT 060200L DC 100T	CERMET RIVESTITO	CCGT060200LC10T	6.35	2.38	0	TS 25	TORX T08
CCGT 060200L DK 100	METALLO DURO	CCGT060200LK100	6.35	2.38	0	TS 25	TORX T08
CCGT 060200L DP 300	METALLO DURO	CCGT060200LP300	6.35	2.38	0	TS 25	TORX T08
CCGT 060202L DC 100	CERMET	CCGT060202LC100	6.35	2.38	0.2	TS 25	TORX T08
CCGT 060202L DC 100T	CERMET RIVESTITO	CCGT060202LC10T	6.35	2.38	0.2	TS 25	TORX T08
CCGT 060202L DK 100	METALLO DURO	CCGT060202LK100	6.35	2.38	0.2	TS 25	TORX T08
CCGT 060202L DP 300	METALLO DURO	CCGT060202LP300	6.35	2.38	0.2	TS 25	TORX T08
CCGT 060204L DC 100	CERMET	CCGT060204LC100	6.35	2.38	0.4	TS 25	TORX T08
CCGT 060204L DC 100T	CERMET RIVESTITO	CCGT060204LC10T	6.35	2.38	0.4	TS 25	TORX T08
CCGT 060204L DK 100	METALLO DURO	CCGT060204LK100	6.35	2.38	0.4	TS 25	TORX T08
CCGT 060204L DP 300	METALLO DURO	CCGT060204LP300	6.35	2.38	0.4	TS 25	TORX T08
CCGT 09T302L DC 100	CERMET	CCGT09T302LC100	9.525	3.97	0.2	TS 4	TORX T15
CCGT 09T302L DC 100T	CERMET RIVESTITO	CCGT09T302LC10T	9.525	3.97	0.2	TS 4	TORX T15
CCGT 09T302L DK 100	METALLO DURO	CCGT09T302LK100	9.525	3.97	0.2	TS 4	TORX T15
CCGT 09T302L DP 300	METALLO DURO	CCGT09T302LP300	9.525	3.97	0.2	TS 4	TORX T15
CCGT 09T304L DC 100	CERMET	CCGT09T304LC100	9.525	3.97	0.4	TS 4	TORX T15
CCGT 09T304L DC 100T	CERMET RIVESTITO	CCGT09T304LC10T	9.525	3.97	0.4	TS 4	TORX T15
CCGT 09T304L DK 100	METALLO DURO	CCGT09T304LK100	9.525	3.97	0.4	TS 4	TORX T15
CCGT 09T304L DP 300	METALLO DURO	CCGT09T304LP300	9.525	3.97	0.4	TS 4	TORX T15

## TPGX ○○○○○○L

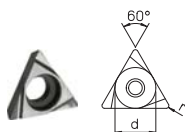

REF.		CODE	d	s	r	⌘	🔑
TPGX 090200L DC 100	CERMET	TPGX090200LC100	5.56	2.38	0	CS250T	TORX T08
TPGX 090200L DC 100T	CERMET RIVESTITO	TPGX090200LC10T	5.56	2.38	0	CS250T	TORX T08
TPGX 090200L DK 100	METALLO DURO	TPGX090200LK100	5.56	2.38	0	CS250T	TORX T08
TPGX 090200L DP 300	METALLO DURO	TPGX090200LP300	5.56	2.38	0	CS250T	TORX T08
TPGX 090202L DC 100	CERMET	TPGX090202LC100	5.56	2.38	0.2	CS250T	TORX T08
TPGX 090202L DC 100T	CERMET RIVESTITO	TPGX090202LC10T	5.56	2.38	0.2	CS250T	TORX T08
TPGX 090202L DK 100	METALLO DURO	TPGX090202LK100	5.56	2.38	0.2	CS250T	TORX T08
TPGX 090202L DP 300	METALLO DURO	TPGX090202LP300	5.56	2.38	0.2	CS250T	TORX T08
TPGX 090204L DC 100	CERMET	TPGX090204LC100	5.56	2.38	0.4	CS250T	TORX T08
TPGX 090204L DC 100T	CERMET RIVESTITO	TPGX090204LC10T	5.56	2.38	0.4	CS250T	TORX T08
TPGX 090204L DK 100	METALLO DURO	TPGX090204LK100	5.56	2.38	0.4	CS250T	TORX T08
TPGX 090204L DP 300	METALLO DURO	TPGX090204LP300	5.56	2.38	0.4	CS250T	TORX T08
TPGX 110300L DC 100	CERMET	TPGX110300LC100	6.35	3.18	0	CS300890T	TORX T08
TPGX 110300L DC 100T	CERMET RIVESTITO	TPGX110300LC10T	6.35	3.18	0	CS300890T	TORX T08
TPGX 110300L DK 100	METALLO DURO	TPGX110300LK100	6.35	3.18	0	CS300890T	TORX T08
TPGX 110300L DP 300	METALLO DURO	TPGX110300LP300	6.35	3.18	0	CS300890T	TORX T08
TPGX 110302L DC 100	CERMET	TPGX110302LC100	6.35	3.18	0.2	CS300890T	TORX T08
TPGX 110302L DC 100T	CERMET RIVESTITO	TPGX110302LC10T	6.35	3.18	0.2	CS300890T	TORX T08
TPGX 110302L DK 100	METALLO DURO	TPGX110302LK100	6.35	3.18	0.2	CS300890T	TORX T08
TPGX 110302L DP 300	METALLO DURO	TPGX110302LP300	6.35	3.18	0.2	CS300890T	TORX T08
TPGX 110304L DC 100	CERMET	TPGX110304LC100	6.35	3.18	0.4	CS300890T	TORX T08
TPGX 110304L DC 100T	CERMET RIVESTITO	TPGX110304LC10T	6.35	3.18	0.4	CS300890T	TORX T08
TPGX 110304L DK 100	METALLO DURO	TPGX110304LK100	6.35	3.18	0.4	CS300890T	TORX T08
TPGX 110304L DP 300	METALLO DURO	TPGX110304LP300	6.35	3.18	0.4	CS300890T	TORX T08

## VITE BLOCCAGGIO INSERTI

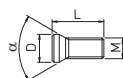

## CHIAVE TORX

REF.	⌘	CODE	M	L	D	α	N·m	REF.	🔑	CODE
TS 21		494010002034	M 2x0.4	3.7	2.7	60°	0,5	TORX T06		101500900600
TS 211		494010002040	M 2x0.4	4	2.7	60°	0,5	TORX T06		101500900600
CS 250 T		494010002565	M 2.5x0.45	6	3.7	60°	1,0	TORX T08		101500900800
CS 300890 T		494010003008	M 3x0.5	8	4.1	90°	1,0	TORX T08		101500900800
TS 25		494010002555	M 2.5x0.45	5.7	3.45	60°	1,0	TORX T08		101500900800
TS 4		494010004008	M 4x0.7	10	5.5	60°	3,0	TORX T15		101500901500
TS 5		494010005009	M 5x0.8	11.5	7	60°	7,5	TORX T25		101500902500

TPGX ○○○○○○

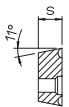
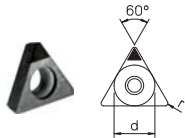

REF.	CODE	d	s	r	TS	TORX
TPGX 090202 D20 MDC	TPGX090202MDC20	5.56	2.38	0.2	CS250T	TORX T08
TPGX 090204 D20 MDC	TPGX090204MDC20	5.56	2.38	0.4	CS250T	TORX T08
TPGX 110302 D20 MDC	TPGX110302MDC20	6.35	3.18	0.2	CS300890T	TORX T08
TPGX 110304 D20 MDC	TPGX110304MDC20	6.35	3.18	0.4	CS300890T	TORX T08
TPGX 090202 D20 CBN	TPGX090202CBN20	5.56	2.38	0.2	CS250T	TORX T08
TPGX 090202 D25 CBN	TPGX090202CBN25	5.56	2.38	0.2	CS250T	TORX T08
TPGX 090204 D20 CBN	TPGX090204CBN20	5.56	2.38	0.4	CS250T	TORX T08
TPGX 090204 D25 CBN	TPGX090204CBN25	5.56	2.38	0.4	CS250T	TORX T08
TPGX 110302 D25 CBN	TPGX110302CBN25	6.35	3.18	0.2	CS300890T	TORX T08
TPGX 110304 D20 CBN	TPGX110304CBN20	6.35	3.18	0.4	CS300890T	TORX T08
TPGX 110304 D25 CBN	TPGX110304CBN25	6.35	3.18	0.4	CS300890T	TORX T08

CCMT ○○○○○○

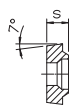
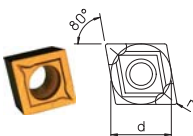

REF.	CODE	d	s	r	TS	TORX
CCMT 060202 DP 100R	CCMT060202P100R	6.35	2.38	0.2	TS 25	TORX T08
CCMT 060202 DP 300	CCMT060202P300	6.35	2.38	0.2	TS 25	TORX T08
CCMT 060204 DP 100R	CCMT060204P100R	6.35	2.38	0.4	TS 25	TORX T08
CCMT 060204 DP 300	CCMT060204P300	6.35	2.38	0.4	TS 25	TORX T08
CCMT 09T304 DP 100R	CCMT09T304P100R	9.525	3.97	0.4	TS 4	TORX T15
CCMT 09T304 DP 300	CCMT09T304P300	9.525	3.97	0.4	TS 4	TORX T15
CCMT 09T308 DP 100R	CCMT09T308P100R	9.525	3.97	0.8	TS 4	TORX T15
CCMT 09T308 DP 300	CCMT09T308P300	9.525	3.97	0.8	TS 4	TORX T15
CCMT 120404 DP 100R	CCMT120404P100R	12.7	4.76	0.4	TS 5	TORX T25
CCMT 120404 DP 300	CCMT120404P300	12.7	4.76	0.4	TS 5	TORX T25
CCMT 120408 DP 100R	CCMT120408P100R	12.7	4.76	0.8	TS 5	TORX T25
CCMT 120408 DP 300	CCMT120408P300	12.7	4.76	0.8	TS 5	TORX T25

QUALITÀ DI BARENATURA

ISO	METALLO DURO	CERMET	CERMET RIVESTITO	METALLO DURO RIVESTITO CVD
P01				
P10		DC100	DC100T	DP100R
P20	DP300			
P30	DP300			
P40				
K01				
K10	DK100	DC100	DC100T	DP100R
K20	DP300			
K30				

DP300	Sgrossatura e finitura. Acciai a basso tenore di carbonio - acciai inox
DK100	Sgrossatura e finitura. Leghe di alluminio Ghise
DP100R	Sgrossatura. Acciai, acciai legati e ghise
DC100	Finitura. Acciai legati in genere e ghise sferoidali
DC100T	Finitura. Acciai legati in genere, acciai inox e ghise sferoidali
D20MDC	Finitura. Leghe di alluminio, materiali non-ferrosi e non-metalli
D20CBN	Finitura. Acciai con elevata durezza superiore 50 HRC (può sostituire la rettifica)
D25CBN	Finitura. Acciai con elevata durezza superiore 50 HRC e taglio interrotto (può sostituire la rettifica)

# U-TRONIC

Teste a CN di medie e grandi dimensioni, applicabili su alesatrici, centri di lavoro e macchine speciali. Lo spostamento della slitta è gestito da un servomotore integrato e direttamente collegato al CN e l'applicazione prevede una flangia di interfaccia che può essere realizzata in versione manuale, automatica, prolungata ed angolare. Oltre alla gamma standard, è disponibile la versione con riduttore integrato e, a richiesta le versioni speciali con foro, doppia slitta, con contrappesi per autobilanciamento.

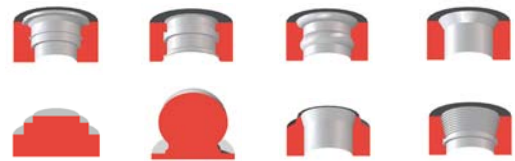
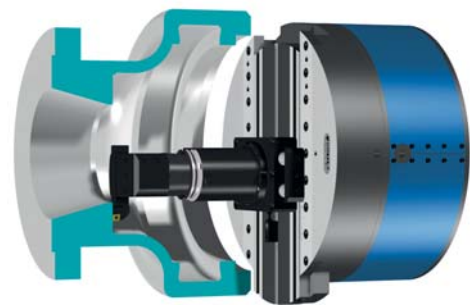
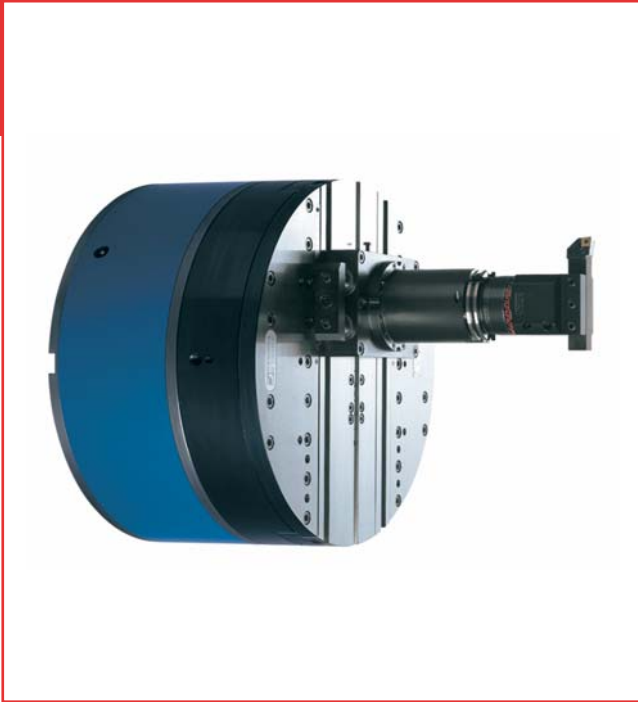

## STANDARD

### SLITTA SINGOLA

UT 3-360 S  
Ø max 800

UT 5-500 S  
Ø max 1000

UT 5-630 S  
Ø max 1250

UT 5-800 S  
Ø max 1400

UT 8-800 S  
Ø max 1600

UT 8-1250 S  
Ø max 2700

UT 8-1000 S  
Ø max 2000

UT 8-1600 S  
Ø max 3200

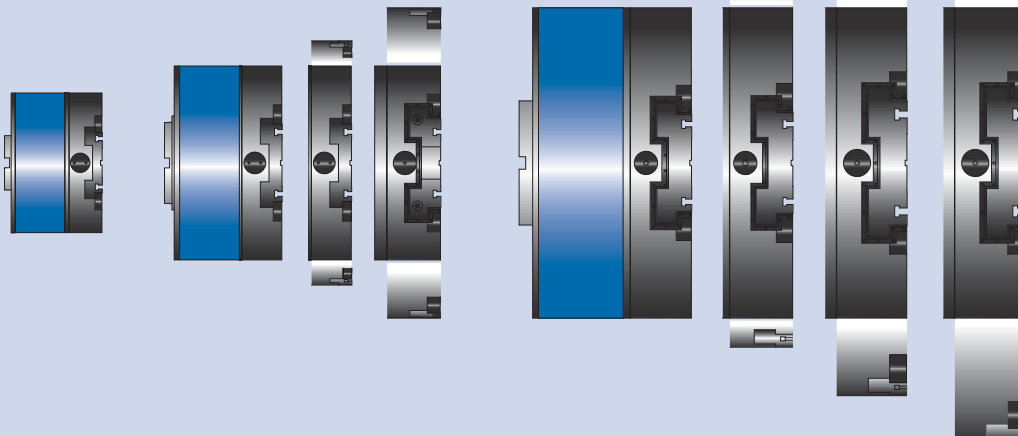

### RIDUTTORE

UT 3-360 S+R  
Ø max 800

UT 5-500 S+R  
Ø max 1000

UT 5-630 S+R  
Ø max 1250

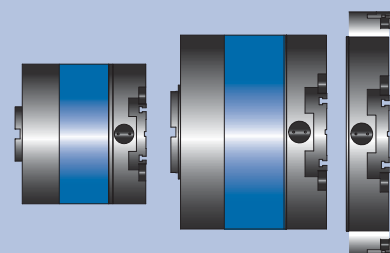

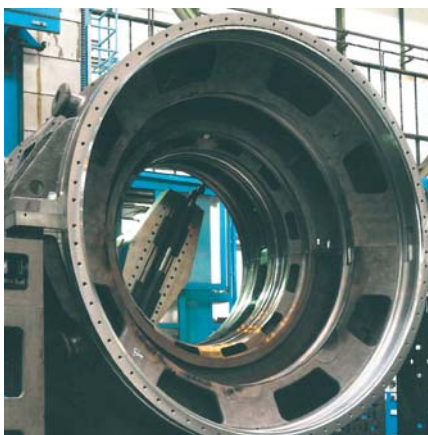
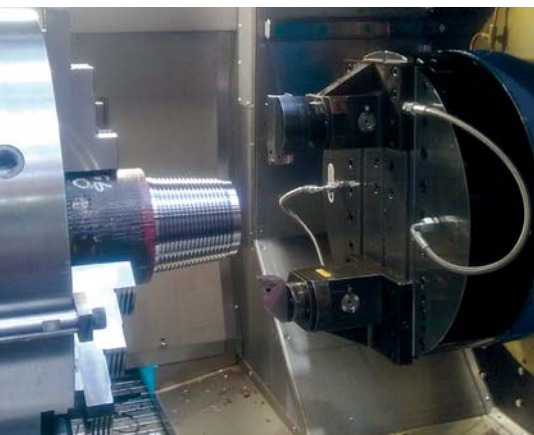
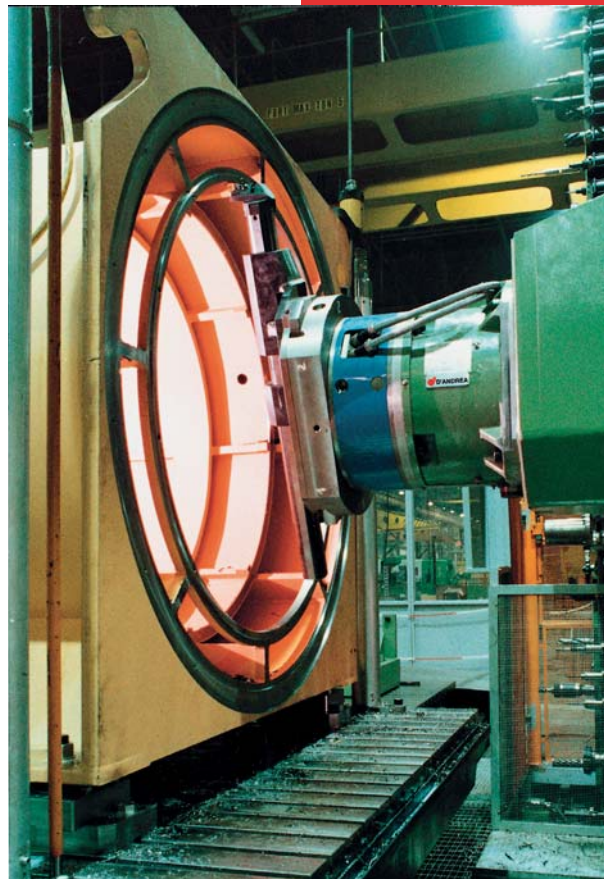
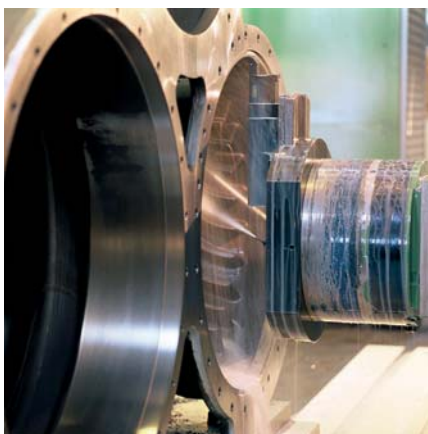
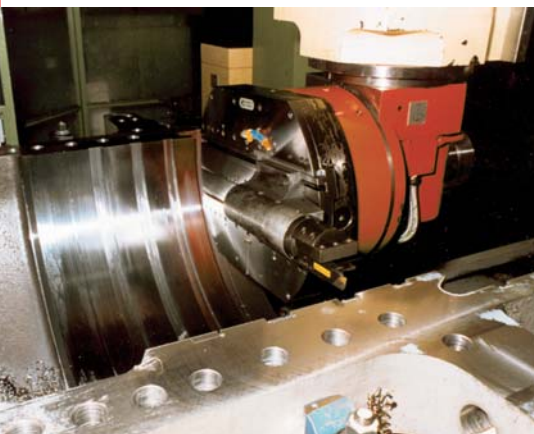

## SPECIALI

### HOLE

UT 5-500 HOLE  
Ø max 1000

UT 5-630 HOLE  
Ø max 1200

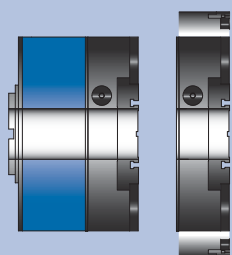

### DOPPIA SLITTA

UT 5-500 D  
Ø max 1000

UT 5-630 D  
Ø max 1200

UT 5-800 D  
Ø max 1400

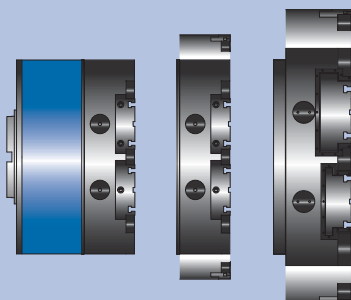

### ALTA VELOCITÀ

UT 3-360BH  
Ø max 600

UT 5-500 BH  
Ø max 900

UT 5-630 BH  
Ø max 1100

UT 8-800 BH  
Ø max 1400

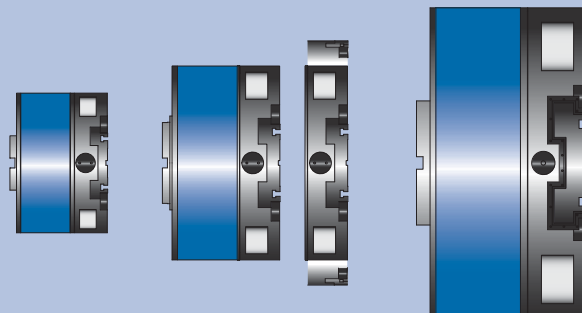

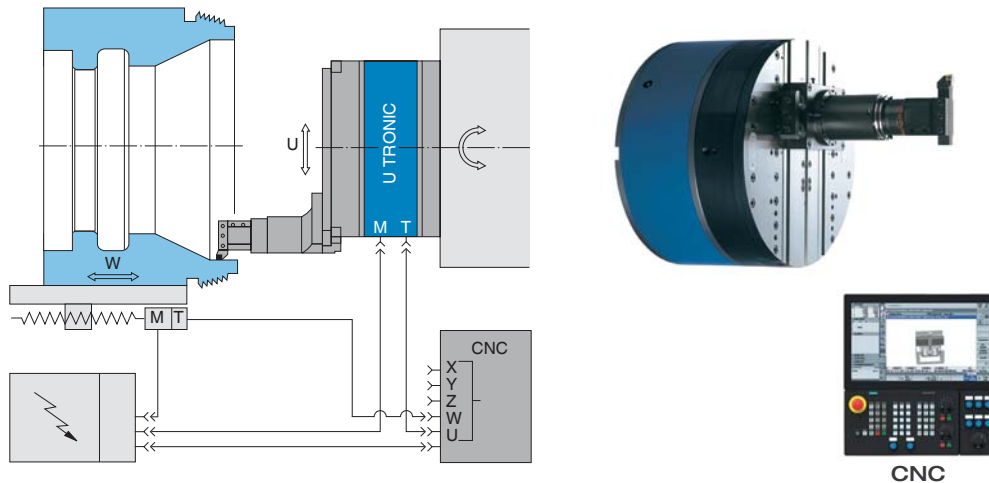

Il controllo delle teste U-TRONIC avviene tramite il collegamento diretto all'asse "U" del controllo numerico della macchina utensile, tramite l'interpolazione degli assi permette di eseguire ogni tipo di operazione di tornitura, alesature, raggiature e operazioni sferiche.

## COMPONENTI

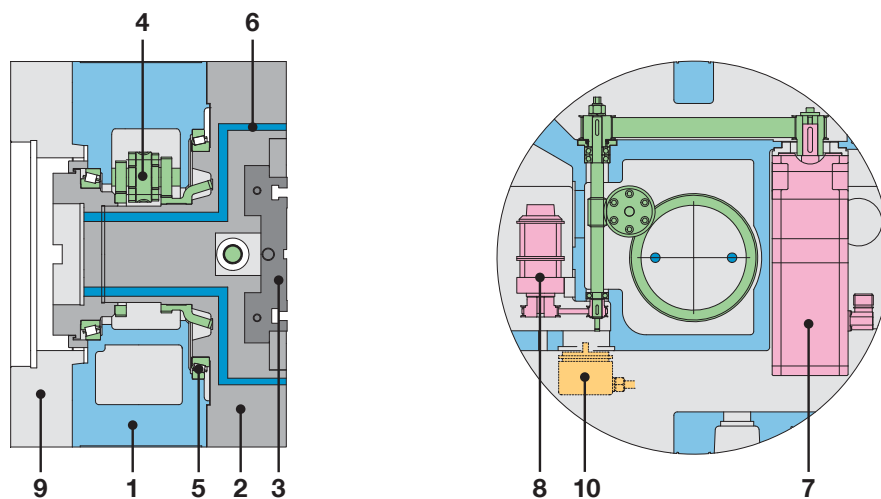

1. Corpo fisso
2. Corpo rotante
3. Slitta portautensili
4. Cinematismo
5. Cuscinetti
6. Passaggio refrigerante
7. Servomotore
8. Microinterruttori di finecorsa
9. Flangia
10. Encoder a richiesta

## PREDISPOSIZIONI

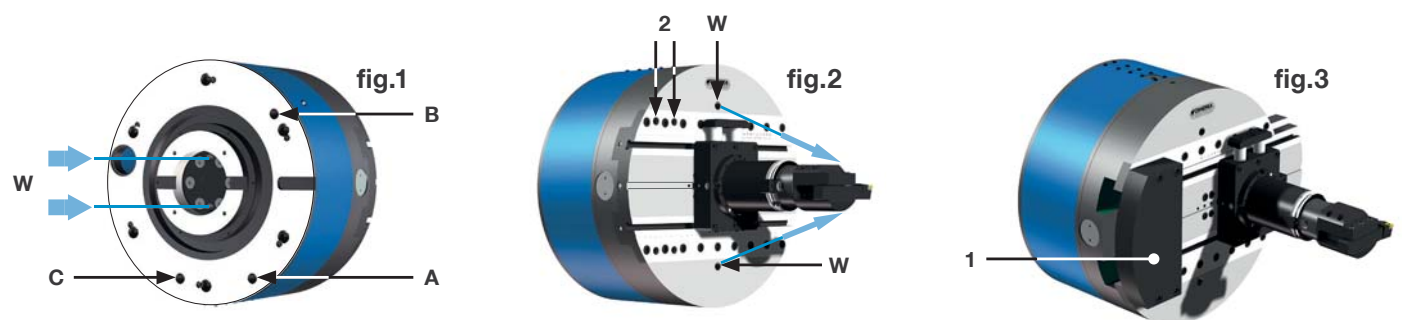

### A-Pressurizzazione interna fig.1

Per evitare che liquido e polvere entrino nella zona del motore, trasduttore e finecorsa, è previsto un foro  $\varnothing 8,5$  (A) per pressurizzare l'interno del corpo fisso con l'ingresso dell'aria a 0,5-1 BAR.

### B-Ingrassatore automatico fig.1

Sulla testa è previsto un foro  $\varnothing 8,5$  (B) per permettere l'inserimento automatico del grasso all'interno della U-TRONIC.

### C-Lubrificazione nebulizzata fig.1

Per lubrificare automaticamente le guide di scorrimento e la vite madre per il trascinamento della slitta portautensili posti nel corpo rotante della U-TRONIC, a richiesta è possibile predisporre la testa per immettere nel foro  $\varnothing 8,5$  (C) un flusso costante minimo di 10 g/h d'olio nebulizzato ad una pressione di 0,5-1 BAR.

### Adduzione liquido refrigerante fig.1-2

All'interno del corpo rotante della U-TRONIC sono previste delle canalizzazioni (W) che permettono il passaggio del liquido refrigerante dal mandrino della macchina sino a due fori filettati posti a fianco della slitta (W). Su tali fori è possibile avvitare dei condotti flessibili e portare il liquido refrigerante direttamente all'utensile. Pressione **Max BAR 40**.

### Bilanciatura fig.3

Per migliorare le condizioni di lavoro e bilanciare la posizione dell'utensile quando risulta spostato rispetto all'asse della U-TRONIC, è possibile applicare dei contrappesi (1) utilizzando i fori filettati (2) posti sul corpo rotante.

Le U-TRONIC si applicano manualmente o automaticamente mediante una flangia per il fissaggio alla macchina utensile e un platello per la rotazione del corpo rotante.

Si applicano manualmente utilizzando una flangia per il fissaggio con attacco rapido camlock, o automaticamente con sistemi palettizzati e appositi connettori.

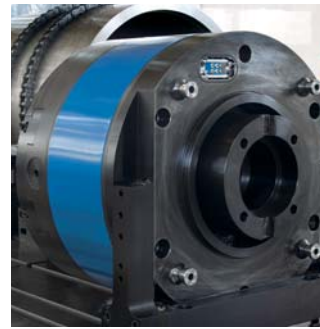
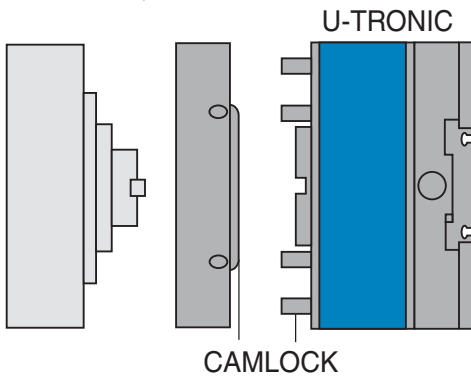

I seguenti layout riportano i dati di base per la costruzione delle flange con attacco rapido camlock.

Le U-TRONIC UT 8-800 S e UT 8-1000 S non prevedono il fissaggio con attacco rapido camlock.

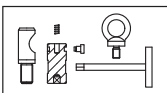

REF	CODE
KIT CAMLOCK UT 360	394200136000
VTC 8x12	100051080012
GOLFARE M10 UT BASE 3	100541100100
MOLLA UT BASE 3 E 5	100551060023
CMC DA 6 UT BASE 3	101500701200
TNT BLOC. CAM 6 UT BASE 3	101601010600
CAMMA ECC. BLOC 6 UT BASE 3	101601020600
PUNTALINO CAMMA 8 UT BASE 3	200100150817

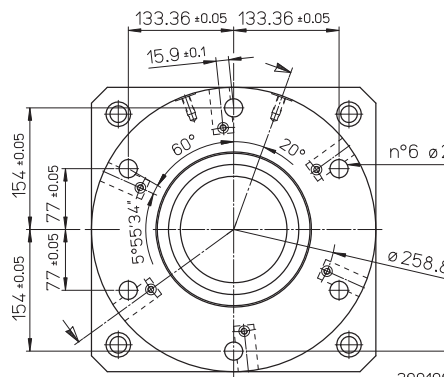

## U-TRONIC 3-360 S

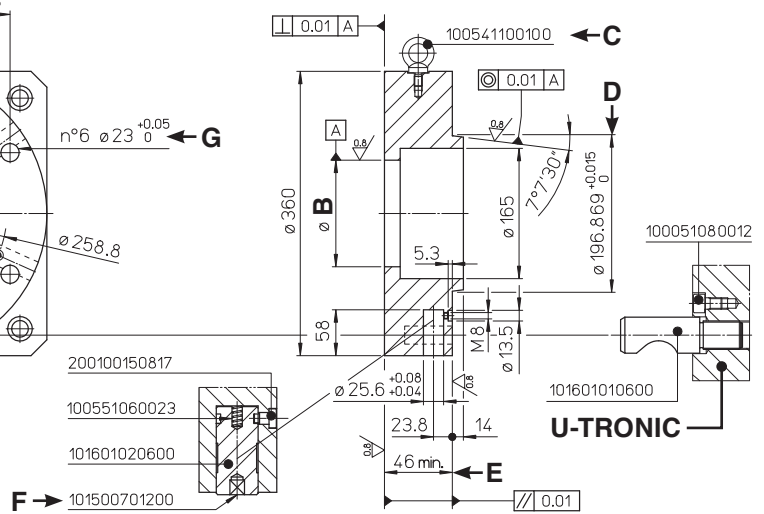

B Centraggio mandrino C Golfare D Controllare con calibro E Quota da controllare in funzione della sporgenza mandrino F Chiave di manovra G Fori prof. min. 46 H Fori prof. min. 53

I seguenti layout riportano i dati di base per la costruzione delle flange con attacco rapido camlock.

Le U-TRONIC UT 8-800 S e UT 8-1000 S non prevedono il fissaggio con attacco rapido camlock.

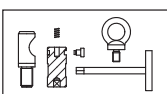

REF	CODE
KIT CAMLOCK UT 500	394200150000
VTC 8x14	100051080014
GOLFARE M16 UT BASE 5	100541100160
MOLLA UT BASE 3 E 5	100551060023
CMC DA 8 UT BASE 5	101500701400
TNT BLOC. CAM 8 UT BASE 5	101601010800
CAMMA ECC. BLOC 6 UT BASE 5	101601020800
PUNTALINO CAMMA 8 UT BASE 5	200100150818

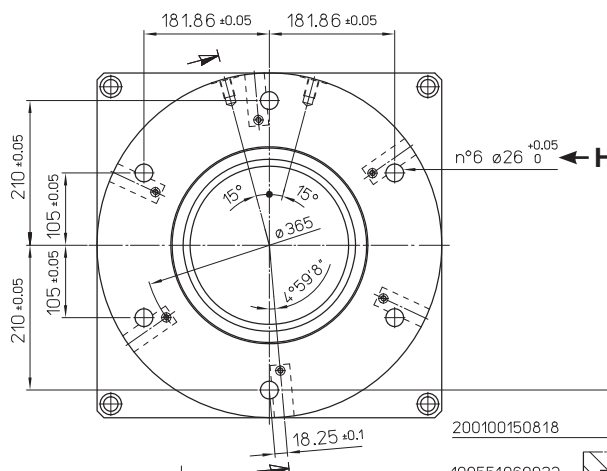

## U-TRONIC 5-500 / 5-630 / 5-800 S

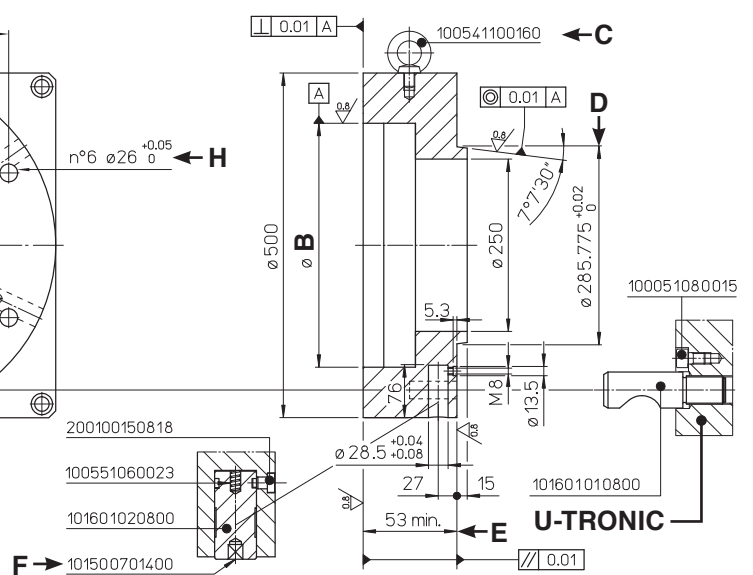

B Centraggio mandrino C Golfare D Controllare con calibro E Quota da controllare in funzione della sporgenza mandrino F Chiave di manovra G Fori prof. min. 46 H Fori prof. min. 53



# U-TRONIC

## CAPACITÀ DI ASPORTAZIONE

Le asportazioni sono indicative per condizioni di lavoro normali su acciai con durezza 160-200 HB, ( $K_s$  medio = 2000 N/mm<sup>2</sup>)  $V_t$  consigliata 120/160 m/min. I valori ottimali ed i tempi di lavoro dovranno essere determinati con delle prove.

### U-TRONIC 3-360 S

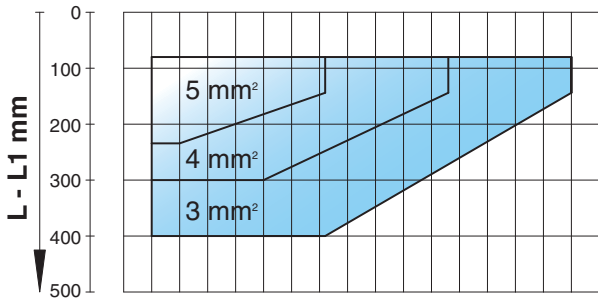
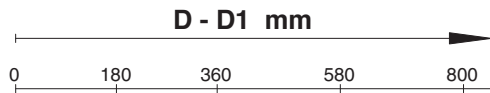
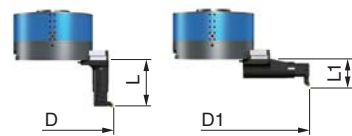

### U-TRONIC 5-500 S

5-630 S

5-800 S

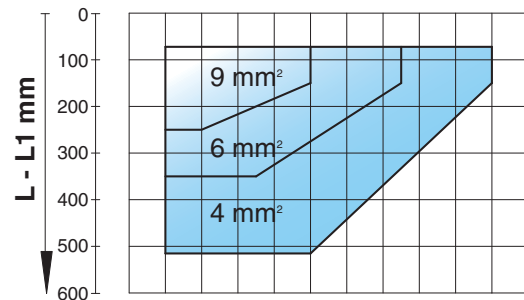
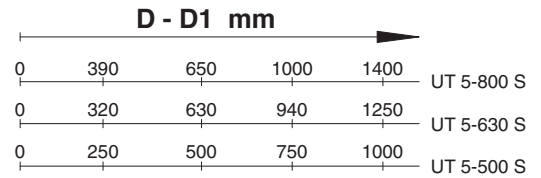
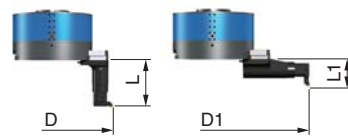

### U-TRONIC 8-800 S

8-1000 S

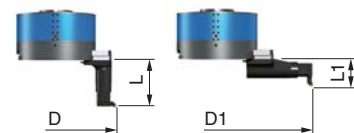
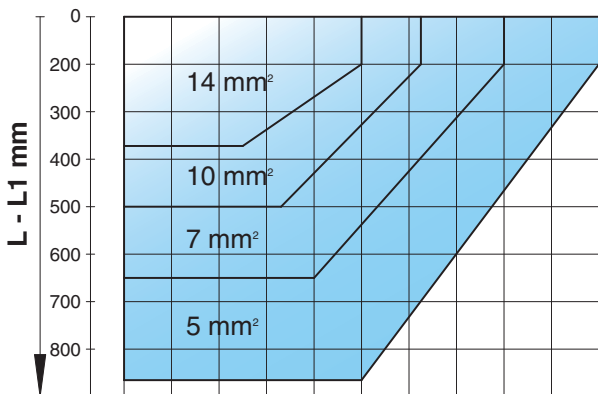
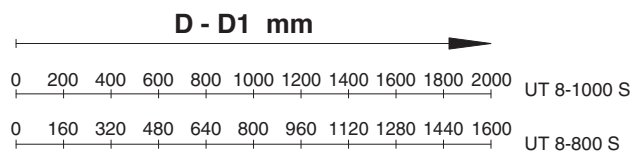

Per un buon impiego della testa U-TRONIC e per salvaguardarne l'integrità è consigliato seguire il grafico sottostante che indica il numero di giri massimo in funzione della corsa della slitta.

## MAX VELOCITÀ DI ROTAZIONE

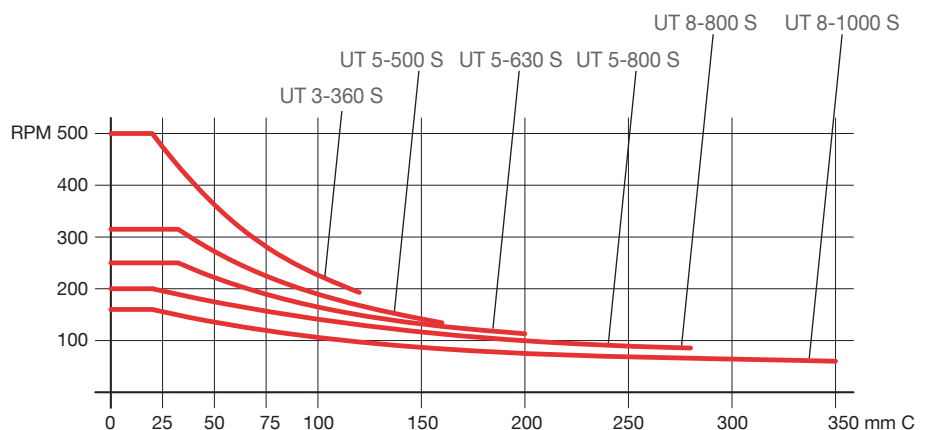

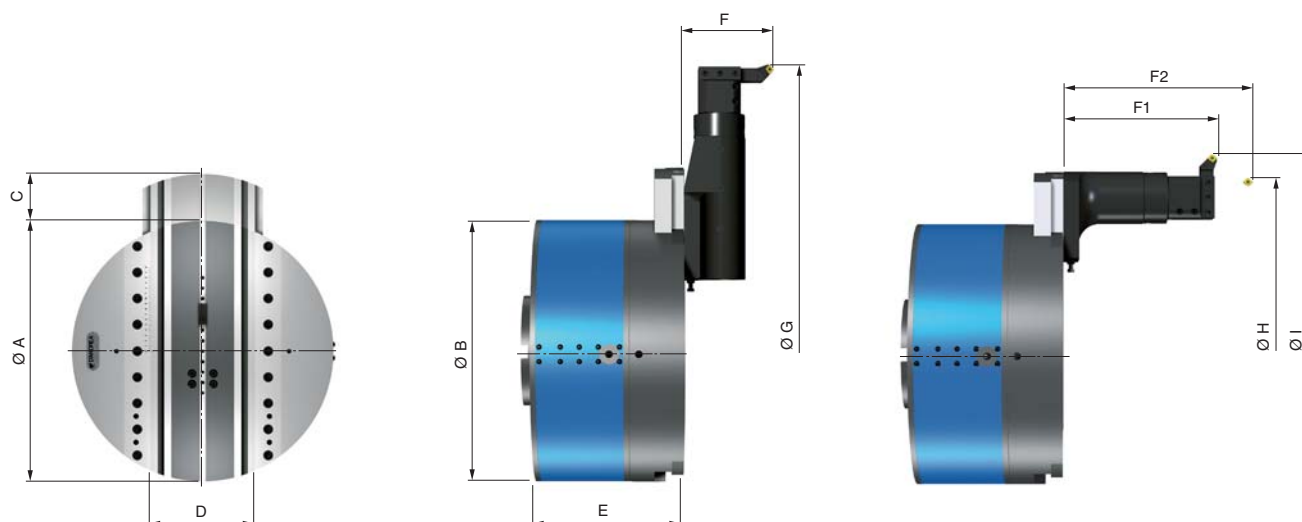

DATI TECNICI		UT 3-360 S	UT 5-500 S	UT 5-630 S	UT 5-800 S	UT 8-800 S	UT 8-1000 S
Ø A	mm	360	500	630	800		1000
Ø B	mm	360	500			800	
C Corsa radiale	mm	120	160	200	250	280	350
D	mm	154.6	199.6		230	250	260
E	mm	235	278.5	282	370	410	415
Ø G x F	mm	800 x 140	1000 x 150	1250 x 150	1400 x 150	1600 x 160	2000 x 160
Ø H x F2	mm	400 x 400	560 x 540	700 x 540	830 x 540	850 x 860	1050 x 860
Ø I x F1	mm	670 x 240	850 x 295	1050 x 295	1300 x 295	1250 x 370	1600 x 370
Max. mm/min	mm/min	1 ÷ 400				1 ÷ 500	
Max. U/min	RPM	500	315	250	200		160
Peso	Kg	130	230	310	530	1000	1200
Forza radiale	daN	400	500			1000	
Momento torcente	daNm	400	800			1000	
Precisione in alesatura		H7					
Max asportazione	mm <sup>2</sup> C40	5	9			14	
Rapido	mm/min	400				500	
Rugosità	Ra	0,8 ~ 1,2					



UT 3-360 S

UT 5-500 S

UT 5-630 S

UT 5-800 S

UT 8-800 S

UT 8-1000 S

REF.	
K02 UT 3-360 S	

REF.	
K02 UT 5-500 S	
K02 UT 5-630 S	
K02 UT 5-800 S	

REF.	
K02 UT 8-800 S	
K02 UT 5-1000 S	

UT 3-360 / 5-500 / 5-630 / 5-800 / 8-800 / 8-1000 S

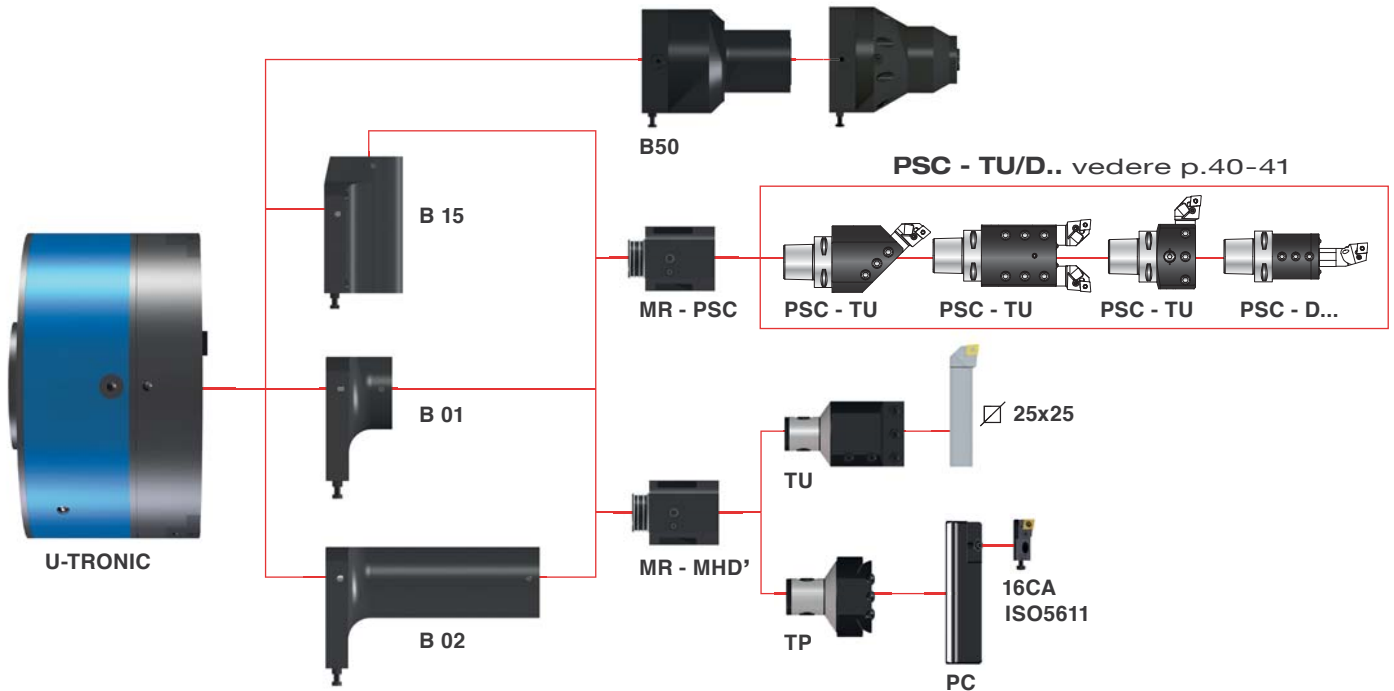

## B01 / B02 / B15 - PSC / MHD'

new

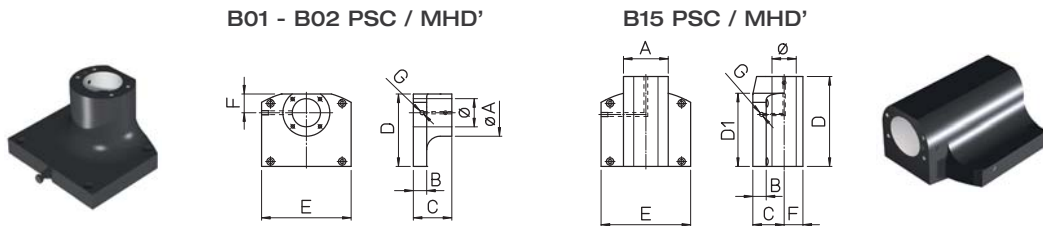

U-TRONIC	REF.	CODE	ØH7	A	B	C	D	D1	E	F	G	kg
UT 3-360 S	B01 PSC63-MHD'80	443006300310	63	105	25	31	137		150	42	G1/8'	3.5
	B02 PSC63-MHD'80	443006301610	63	105	25	161	137		150	42	G1/8'	11
	B15 PSC63-MHD'80	445006301210	63	105	25	60	121		150	42	G1/8'	8
UT 5-500 S / 5-630 S / 5-800 S	B01 PSC63-MHD'80	443006302002	63	105	30	86	162		200	42	G1/8'	11
	B02 PSC63-MHD'80	443006303310	63	105	30	331	162		200	42	G1/8'	23.5
	B15 PSC63-MHD'80	445006302010	63	105	30	70	201	170	200	42	G1/8'	6.5
	B01 PSC80-MHD'80	443007500710	75	133	30	71	185		200	50	G1/8'	10.5
	B02 PSC80-MHD'80	443007503160	75	133	35	316	235		200	50	G1/8'	33
	B15 PSC80-MHD'80	445007502620	75	133	35	85	262	200	200	50	G1/8'	31
UT 8-800 S / 8-1000 S	B01 PSC80-MHD'80	443007501460	75	133	30	146	182		250	50	G1/4'	18.5
	B02 PSC80-MHD'80	443007506360	75	133	45	636	182		250	50	G1/4'	64.5
	B15 PSC80-MHD'80	445007503000	75	133	30	85	300	200	250	50	G1/4'	35

## MR - PSC / MHD'

new

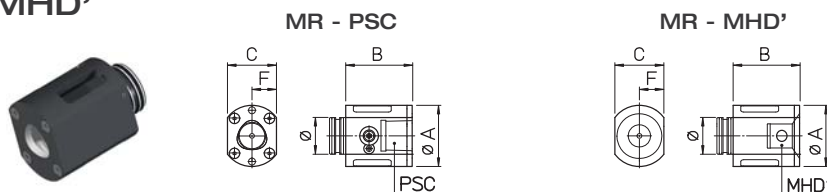

U-TRONIC	REF.	CODE	Øg6	PSC	MHD'	A	B	C	F	kg
UT 3 / 5 ... S	MR - PSC 63	450206301050	63	63		105	114	84	42	6.5
	MR - MHD'80	450208001050	63		80	105	114	84	42	6
UT 5 / 8 ... S	MR - PSC 80	450208001335	75	80		133	129	100	50	11
	MR - MHD'80	450208001330	75		80	133	129	100	50	11

# PORTAUTENSILI E ACCESSORI PSC-MHD'

## K03 PSC



1 B 01 - PSC 63-80 / MHD' 63-80  
1 B 02 - PSC 63-80 / MHD' 63-80  
1 B 15 - PSC 63-80 / MHD' 63-80  
1 MR - PSC 63-80

REF.	CODE
KIT K03 PSC 63 UT 3-360 S	501703259501
KIT K03 PSC 63 UT 5-500 / 5-630 / 5-800 S	501705009501
KIT K03 PSC 80 UT 5-500 / 5-630 / 5-800 S	501705009502
KIT K03 PSC 80 UT 8-800 / 8-1000 S	501708009501

## K03 MHD'



1 B 01 - PSC 63-80 / MHD' 63-80  
1 B 02 - PSC 63-80 / MHD' 63-80  
1 B 15 - PSC 63-80 / MHD' 63-80  
1 MR - MHD' 80  
1 TU - MHD' 50-63-80

REF.	CODE
KIT K03 UT 3-360 S	501703259500
KIT K03 UT 5-500 / 5-630 / 5-800 S	501705009500
KIT K03 UT 8-800 / 8-1000 S	501708009500

## TU - MHD'

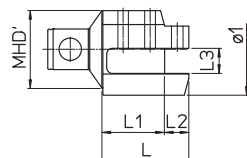

U-TRONIC	REF.	CODE	MHD'	Ø1	L	L1	L2	L3	kg
UT 3 / 5 / 8 ... S ♦	TU 50/60.16	460505016001	50	60	60	44	16	16	1.2
UT 3 / 5 / 8 ... S ♦	TU 63/75.20	460506320001	63	75	75	55	20	20	4
UT 3 / 5 / 8 ... S •	TU 80/95.25	460508025001	80	95	90	65	25	25	3.6

♦ Utilizzare con RD 80/ .... • Fornibile a Richiesta con Passaggio refrigerante

## TP - MHD'

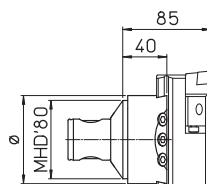

U-TRONIC	REF.	CODE	Ø	kg
UT 3-360 S	TP 80/90.50	460408050001	90	2.3
UT 5-500 S / 5-630 S / 5-800 S	TP 80/90.50	460408050001	90	2.3
UT 8-800 S / 8-1000 S	TP 80/125.50	460408050002	125	3.2

## PC

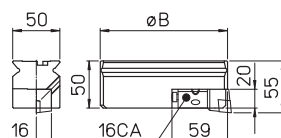

U-TRONIC	REF.	CODE	Ø B	kg
UT 3-360 S	PC 11.50	433050160950	95	1.3
UT 5-500 S / 5-630 S / 5-800 S	PC 12.50	433050161350	135	2
	PC 13.50	433050162000	200	3.2
UT 8-800 S / 8-1000 S	PC 14.50	433050163000	300	5

## CARTUCCE 16CA ISO 5611



PGTNL16CA-16



PCLNL16CA-12



PSSNL16CA-12



PSSNL16CA-12

CODE	CODE	CODE	CODE
483010161001	483010161002	483010161003	483010161004

## PORTAUTENSILI A CAMBIO AUTOMATICO B50 PSC - MHD'



fig.1



fig.1

U-TRONIC	REF.	U-TRONIC	REF.
UT 3-360 S	B50 MHD' HSK - A63 - A100	UT 3-360 S	B50 PSC 63-80
UT 5-500 S / 5-630 S / 5-800 S	B50 MHD' DIN69871-A-B 50	UT 5-500 S / 5-630 S / 5-800 S	B50 PSC 63-80
UT 8-800 S / 8-1000 S	B50 MHD' MAS BT50	UT 8-800 S / 8-1000 S	B50 PSC 63-80

A richiesta sono fornibili portautensili a cambio automatico dell'utensile B50, speciali e OLEODINAMICI (fig.1)

# U-TRONIC

## SOLUZIONI SPECIALI DISPONIBILI A RICHIESTA

Tra queste la U-TRONIC S+R che a differenza della versione standard U-TRONIC S, hanno al loro interno un riduttore 1:4 per permettere di aumentarne la coppia di lavoro e quindi l'asportazione.

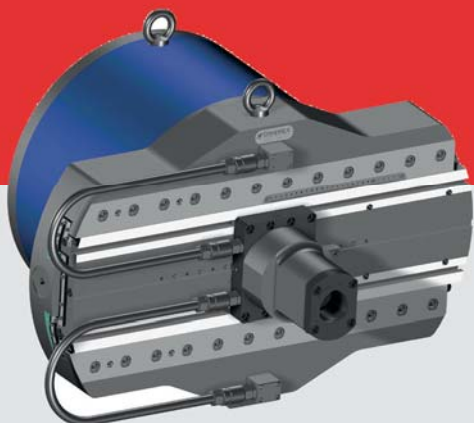

Riduttore



Prolungate



Doppia Slitta

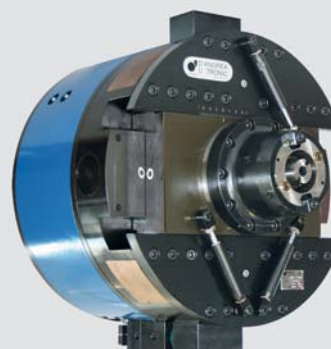

Alta velocità

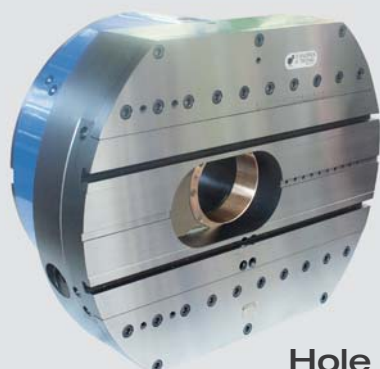

Hole



Flange  
Angolari

# D'ANDREA

Via Garbagnate, 71 - 20045 Lainate (MI) Italy  
t. +39 02.937532.1 - f. +39 02.93753240  
info@dandrea.com - www.dandrea.com



12/22  
Cod. 181001001010

